

SECTION 12.3 INTERCHANGE AREA MANAGEMENT PLAN

An Interchange Area Management Plan (IAMP) has been prepared for the Interstate-82 (I-82)/US 730 Interchange in Umatilla, Oregon. The following section provides an overview of the purpose and intent of the IAMP and defines: the interchange function, the project goals and objectives, and the study area. These elements have been defined through a collaborative effort between the project Technical Advisory Committee (TAC) and Public Advisory Committee (PAC).



12.3.100 PURPOSE AND INTENT

The IAMP is a strategic transportation plan that is designed to protect the long-term function of the Interstate 82 (I-82)/US 730 interchange by preserving the capacity of the interchange while providing safe and efficient operations between connecting roadways. The IAMP will identify land use management strategies, short-term and long-term transportation improvements, access management goals, and strategies to fund identified improvements.

The intent is that the IAMP planning efforts will result in policies, ordinances, and other provisions that will be adopted into the City of Umatilla and Umatilla County's Transportation System Plan (TSP) and Comprehensive Plan. The IAMP will also be adopted by the Oregon Transportation Commission (OTC) as an amendment to the Oregon Highway Plan.

12.3.110 Problem Statement

The signalized intersections of Brownell Boulevard/US 730 and the southbound I-82/US 730 terminal are located within close proximity of one another resulting in undesirable operations. The signals have been coordinated in an effort to improve intersection operations. Nevertheless, queuing problems associated with truck traffic accessing the Umatilla Port of Entry (POE) weigh station continue to occur at the two intersections. This condition varies by season due to increase of trucks during mid-summer and fall harvests.

The Port of Entry and weigh station is located on the northwest corner of Brownell Boulevard/US 730 intersection which coincides with the northwest quadrant of the I-82/US 730 interchange. A truck stop, restaurant, fueling station and other commercial development is located in the southwest quadrant. East of the interchange is primarily vacant land within the City of Umatilla Urban Growth Area. This land is zoned exclusive farm use, tourism commercial or public facilities. The City is interested in the economic development potential of this area and would like to develop a local street network plan that supports the safe and efficient operation of the interchange and the US 730/US 395 intersection located within the interchange influence area.

12.3.120 Interchange Description

The I-82/US 730 interchange is an urban interchange that connects US 730 and US 395 with I-82. It is the only interchange serving Umatilla. The interchange is also important for interstate freight travel, as it provides access to the Umatilla POE for trucks entering Oregon from Washington and US 395, a designated freight route. US 730, which is also locally known as 6th Street through Umatilla, provides one of two east-west connections between downtown Umatilla and the McNary area of Umatilla, making it a vital connection to the city. Beyond Umatilla, US 730 connects to I-84 southwest of Irrigon and to US 12 in Washington to the east.

The land uses within the immediate vicinity of the interchange are primarily commercial on the west side and vacant on the east side.

12.3.121 Interchange Function Statement

Following is the function and policy definition for the I-82/US 730 Interchange:

“The primary function of the I-82/US 730 interchange is to facilitate statewide and inter-urban and inter-regional travel to/from the I-82 corridor. A secondary function is to provide east-west interregional connectivity across I-82 for the City of Umatilla and surrounding rural land uses. I-82 is a short, but significant interstate highway that connects the state of Washington to the I-84 corridor.”

12.3.130 Interchange Management Study Area





To provide a comprehensive study and to achieve effective results, the Interchange Management Study Area (IMSA) includes developable and re-developable properties and major roadways that would significantly affect the interchange function over the next 20 years. The IMSA includes properties within ½-mile, and in some cases beyond, from the existing I-82 interchange as defined by the IAMP Guidelines. The IMSA also takes into account facilities and properties that will impact the operations of the interchange and any natural or cultural resources in the vicinity of the interchange.

The IMSA map is shown in *Figure 12.3-1*. *Figure 12.3-1* identifies key features and boundaries of the area included in the IAMP. As shown on the IMSA map, two study boundaries are identified: the IAMP Operations and Access Study area and the Land Use Study Area. The following describes the criteria used to create the IMSA map.



H:\proj\file\10369 - I-82 US 730 IAMP\GIS\UmatillaBaseMap.mxd

LEGEND

-  Minimum 1320' IAMP Limits
-  Land Use Study Area
-  Operations/Access Study Area
-  Umatilla UGB

**INTERCHANGE MANAGEMENT STUDY AREA
UMATILLA, OREGON**

FIGURE

12.3.131 Operations and Access Study Area

The Operations and Access Study Area includes all access points and intersections within ¼-mile of the existing I-82/US 730 interchange and encompass key intersections that have potential to affect traffic operations in the interchange area over the planning period. This study boundary identifies the area for which operational analysis will be completed and the area that will be considered in the Access Management Plan element of the IAMP. The study intersections include:

I-82/US 730 Northbound Terminal

I-82/US 730 Southbound Terminal

US 730 / US 395

US 730 / Lind Road

US 730 / Scaplehorn Road

US 730 / Private Driveway (Umatilla Self Storage business) between Scaplehorn Road and Northbound I-82 ramp

US 730 / Brownell Boulevard

US 730 / Port or Entry Entrance Driveway

US 730 / two private business driveways (Crossroads)

US 730 / Eisele Drive

US 730 / River Road

US 395 / Margaret Avenue

US 395 / Power City Road

12.3.132 Land Use Study Area

The Land Use Study Area includes all properties located roughly within a ½-mile of the interchange. The Land Use Study Area extends beyond a ½-mile in places to incorporate developable and re-developable properties that are expected to significantly affect the interchange function over the next 20 years. Properties identified with potential to affect the interchange include those that are expected to utilize the interchange as their primary connection to I-82 or those that may be necessary to examine to improve local circulation.

12.3.140 Goals and Objectives

The primary goal of the IAMP process is to protect the function of the interchange by anticipating changes in land use and traffic patterns and planning for necessary improvements over a 20-year planning horizon. As stated in Policy 3C of the 1999 Oregon Highway Plan, “*it is the policy of the State of Oregon to plan for and manage grade-separated interchange areas to ensure safe and efficient operation between connecting roadways.*” From this definition, the objectives of the I-82 / US 730 IAMP are to:

- Refine and prioritize improvements needed to maintain acceptable traffic operations at the interchange while providing safe access to adjacent land uses;

- Provide for efficient connectivity, right-of-way, and access control in the Interchange Management Study Area (IMSA);
- Consider the surrounding contextual land use and roadway network;
- Provide plans for improved local street connectivity in the IMSA (see definition below) while limiting cul-de-sacs or other non-connected streets;
- Evaluate existing and potential land use designations, intensities, conditions, and actions that could have favorable effect on the facility or an adverse effect on the facility;
- Collaborate throughout the planning process with design professionals, jurisdictional representatives, developers, and local property owners.
- Comply with the intent of Statewide Planning Goal 1: Public Involvement, 2: Land Use Planning, 5: Natural Resources, 6: Air, Water and Land Resources Quality, 7: Areas Subject to Natural hazards, 8: Recreation Needs, 9: Economic Development, 12: Transportation, and 14: Urban Growth Boundaries.
- Develop policies and implementation measures that support the goals of this project for local consideration and adoption into the City and County comprehensive plans, transportation system plans, and zoning ordinances, as appropriate.

12.3.150 Evaluation Criteria

Based on the above objectives, the following evaluation criteria were assembled to ensure that each concept developed throughout the project would be evaluated for consistency with the overall intent of the community and the project. The six evaluation criteria categories are outlined below:

- **Transportation Operations:** This category consists of those criteria that assess the ability for all modes to travel through and within the study area. Special considerations within this category include safety, local connectivity and mobility, including freight mobility.
- **Land Use:** This category consists of those criteria that assess right-of-way impacts, consistency with adopted land use and economic development plans, transportation capacity impacts of changes in land use intensity, impacts to utilities, and impacts to existing and proposed developments.
- **Economic Development:** This category consists of those criteria that assess the potential for short-term (1-5 years), mid-term (5-15 years), and long-term growth (15-25 years) for areas within the vicinity of the interchange.
- **Cost:** This category consists of those criteria that assess the practicality of a design concept from a construction cost and feasibility perspective.

- Environmental, Social, and Equity factors: This category consists of those criteria that assess the degree to which a concept is compatible with the natural and built environment including environmental (i.e., storm water drainage and hazardous waste) and socioeconomic (i.e., stakeholders' needs) impacts.
- Accessibility: This category consists of those criteria that assess the ability to access properties and businesses within the IMSA to/from the regional infrastructure network including the balance between local access and roadway function, future access for undeveloped properties, and adherence to the access spacing standards.

12.3.160 Development of the IAMP

The I-82/US 730 IAMP was guided by the Technical Advisory Committee (TAC) and Public Advisory Committee (PAC), as well as area residents and business owners. Regular TAC and PAC meetings held throughout the course of the project provided opportunities for the two committees to review and guide the technical analysis prepared by the consultant team and the overall project direction.

12.3.161 Public Involvement

In addition to the regular TAC and PAC meetings, local citizens, property owners, and business owners provided their input by participating in three public workshops. The first workshop provided participants with background information on the project and then gave them the opportunity to develop and present their ideas for design concepts. At the second workshop, participants provided their input on the design concepts that had previously been developed. The third workshop focused on a review of the draft IAMP. Members of the public also submitted comments directly to the project management team either through correspondence or by attending a TAC or PAC meeting. In addition, adoption of the plan included public hearings before the City of Umatilla Planning Commission and Council and the Oregon Transportation Commission.

12.3.170 IAMP Organization and Methodology

The development of the I-82/US 730 IAMP began in January 2010 with the first meeting of the consultant team and City and ODOT staff. Work with the TAC and PAC began shortly thereafter in February 2010. These groups participated in an extensive process that involved reviewing existing and future transportation conditions, future land use analyses, interchange design and local access and circulation concepts, and financing options.

Sections 12.3.100 through 12.3.900 provide the main substance of the plan. These are supplemented by Technical Appendices in Volume 2 of the original final document prepared by Kittleson & Associates, Inc. which contains the technical memoranda documenting each step in the process and is included in this plan as a separate document and made a part hereof by this reference.

12.3.200 INTERAGENCY AND PUBLIC INVOLVEMENT PROGRAM

As part of the I-82/US 730 Interchange Area Management Plan (IAMP), interagency and public involvement occurred through: a kick-off meeting with agency staff; a Technical Advisory Committee (TAC) and a Public Advisory Committee (PAC) that had regular meetings; three public workshops involving local citizens, property owners, and business owners; a joint work session of the City of Umatilla Planning Commission and City Council that was open to the public; and public adoption hearings in front of the City of Umatilla Planning Commission and Council and the Oregon Transportation Commission. An overview of the TAC and PAC meetings and public workshops is summarized below.

12.3.210 Technical Advisory and Public Advisory Committees

The TAC and PAC guided the planning work and were responsible for reviewing all work products, providing input on all planning recommendations, such as the IMSA, goals and objectives, technical analysis, and the proposed concepts. Ultimately the TAC and PAC helped select the preferred interchange form, local circulation/access, land use management, and coordination elements of the IAMP. In addition, a Project Management Team (PMT) performed a coordination function, planning and executing project management tasks related to project schedule and meeting logistics. The PMT included representation from ODOT, the City of Umatilla, and the consultant team and were all members of the TAC.

Membership on the TAC and PAC was established through input from City and ODOT representatives. A proposed TAC and PAC membership roster was presented and finalized at a project kick-off meeting held January 6, 2010.

The TAC members were selected in order to provide representation from key components of interested government agencies. PAC members were selected in order to provide a good representation of City officials, area property and business owners, and other interested citizen groups. In addition to the PAC members, a number of area property and business owners attended PAC meetings and participated in the process.

12.3.220 Public Involvement Plan

To ensure that adequate project coordination and public participation occurred throughout the development of the I-82/US 730 IAMP, a series of TAC and PAC meetings, public workshops, and public joint work sessions were held over the course of the project. The City of Umatilla also conducted public hearings to adopt the plan.

12.3.300 PLAN AND POLICY REVIEW

One of the project objectives of the IAMP is to ensure that the plan is consistent with local and state transportation policies and standards. To meet this objective, a review and evaluation of existing plans, policies, standards, and laws that are relevant to the IMSA was conducted. A summary of the documents reviewed is provided below. Detailed information from this review can be found in the Technical Appendix.

12.3.310 Documents Reviewed

The following transportation and land use plans were reviewed for policies and regulations applicable to the I-82/US 730 Interchange.

12.3.310(1) State/ODOT

Statewide Planning Goal 1 (Public Involvement), Goal 2 (Land Use Planning), Goal 3 (Agriculture), Goal 5 (Natural Resources, Scenic and Historic Areas, and Open Spaces), Goal 6 (Air, Water and Land Resources Quality), Goal 7 (Areas Subject to Natural Hazards), Goal 8 (Recreational Needs), Goal 9 (Economic Development), Goal 12 (Transportation), and Goal 14 (Urbanization)

Oregon Transportation Plan (2006)

Oregon Highway Plan (1999)

Oregon Bicycle and Pedestrian Plan (1995)

Oregon Rail Plan (2001)

Oregon Administrative Rule 660, Division 12 (Transportation Planning Rule)

Oregon Administrative Rule 731, Division 15 (Coordination Rules)

Oregon Administrative Rule 734, Division 51 (Access Management Rule)

Oregon Revised Statute Title 31, Highways, Roads, Bridges, and Ferries

Highway Design Manual (2003)

12.3.310(2) Local

Join Management Agreement, City of Umatilla and Umatilla County (1996)

Umatilla County Comprehensive Plan (1983, Amended)

Umatilla County Transportation System Plan (2002)

Umatilla County Development Code (Revised, 2009)

City of Umatilla Comprehensive Plan

City of Umatilla Transportation System Plan (2001)

City of Umatilla Zoning Code

12.3.320 Consistency with Existing Plans

The IAMP was developed to be consistent with local and state transportation policies. The review of local policies and regulations did not reveal conflicts with the primary goal of the IAMP to protect the function of the interchange, but at the same time, the existing regulatory tools also do not adequately address the future transportation needs in the area. Additional requirements regarding access management, local street connectivity, and transportation financing must be adopted if the transportation system in this area of Umatilla is going to support future planned growth.

12.3.400 EXISTING TRANSPORTATION/LAND USE CONDITIONS



This section provides a review of existing land uses and transportation facilities as well as natural and cultural resources within the vicinity of the I-82/US 730 interchange. As shown in *Figure 12.3-2*, this is the first full interchange for southbound traffic entering from Washington and the only interchange serving Umatilla. The information identified in this section provides a basis for identifying opportunities and constraints for meeting the goals and objectives of the IAMP.

12.3.401 Interchange Management Study Area

The Interchange Management Study Area (IMSA), depicted in *Figure 12.3-3*, defines the extent of the land use and traffic operations review. As the figure shows, the study includes an Operations and Access Study Area and a Land Use Study Area. The Land Use Study Area includes the areas with trip generation potential that are expected to have a direct affect on the design and function of the interchange. Generally speaking, land uses outside of the IMSA area are not anticipated to directly impact the function of the interchange. This is because these properties do not directly access the interchange, have other travel route options within Umatilla besides US 730, or have limited potential to generate new trips (e.g. the land is already



LEGEND

-  Interchange Management Study Area
-  Umatilla City Limits

**STUDY AREA VICINITY
UMATILLA, OREGON**





FIGURE

Figure 12.3-2

H:\profile\110369 - I-82 US 730 IAMP\GIS\UmatillaStudyVicinity.mxd



LEGEND

-  Minimum 1320' IAMP Limits
-  Land Use Study Area
-  Operations/Access Study Area
-  Umatilla UGB

**INTERCHANGE MANAGEMENT STUDY AREA
UMATILLA, OREGON**

FIGURE

H:\profile\110369 - I-82 US 730 IAMP\GIS\UmatillaBaseMap.mxd

developed, the land has limited redevelopment potential, or the land is outside of Umatilla's Urban Growth Boundary [UGB]).

Figure 12.3-3 also outlines the Interchange Operations/Access Review Area. The operations and access management of intersections and driveways within this area is the subject of analysis described later in this section.

12.3.410 Existing Land Use

Pursuant to the requirements stated in the Oregon Administrative Rule 734-051-0155 for the preparation of an IAMP, a land use inventory was prepared for the IMSA. This section provides a description of the existing land-use patterns and zoning regulations that currently exist within the IMSA.

12.3.411 Existing Zoning

As shown in *Figure 12.3-4*, land within the IMSA is a patchwork of incorporated parcels, unincorporated land within the City of Umatilla's urban growth boundary (UGB), and unincorporated county land. A large portion of the IMSA is county zoned, but within the city's UGB, and governed by a Joint Management Agreement (JMA). Areas within the UGB that are not yet annexed to the city are considered part of the Urban Growth Area (UGA).⁴⁴

12.3.411(1) Umatilla County Zoning

For unincorporated areas within the IMSA, County zoning and development regulations apply. County zoning within the City's UGB lies east of I-82 and west of Devore Road (north of US 730) and west of US 395 (south of US 730). While it is clear from the inclusion of these areas in the UGB that urban uses are intended, until which time land is annexed to the City and City zoning is applied, development and redevelopment are dictated by what is allowed by County ordinances. In the case of areas governed by the JMA, the County's 1972 Zoning Ordinance is the regulating document. Below is an overview of County zone designations in the IMSA.

Exclusive Farm Use (FI) - EFU zoning is designed to maintain the agricultural economy of the county by reserving farmland for exclusive agricultural use. In addition to the propagation and harvesting of farm or forest products and associated residential and farm buildings, schools and churches are permitted outright in this zone. Uses permitted conditionally include commercial activities associated with farm and forest uses, parks and playgrounds, golf courses, and personal use airports.

⁴⁴Areas outside city limits within the UGB retain county zoning, but are governed by the JMA and future urban zoning would be determined by the City of Umatilla's Comprehensive Plan Map land use designations. A locally adopted "City of Umatilla Plan Map" depicts both City zoning and plan map designations. However, the plan designations more closely resemble existing (i.e., low intensity rural) uses and do not reflect the City's future growth needs. The City is in the process of developing a work program that will analyze the City's future economic development and employment needs. A legislative amendment updating the City's plan map is expected to be one of the outcomes of the work program, but this City-initiated process is not expected to be complete prior to the completion of the IAMP.

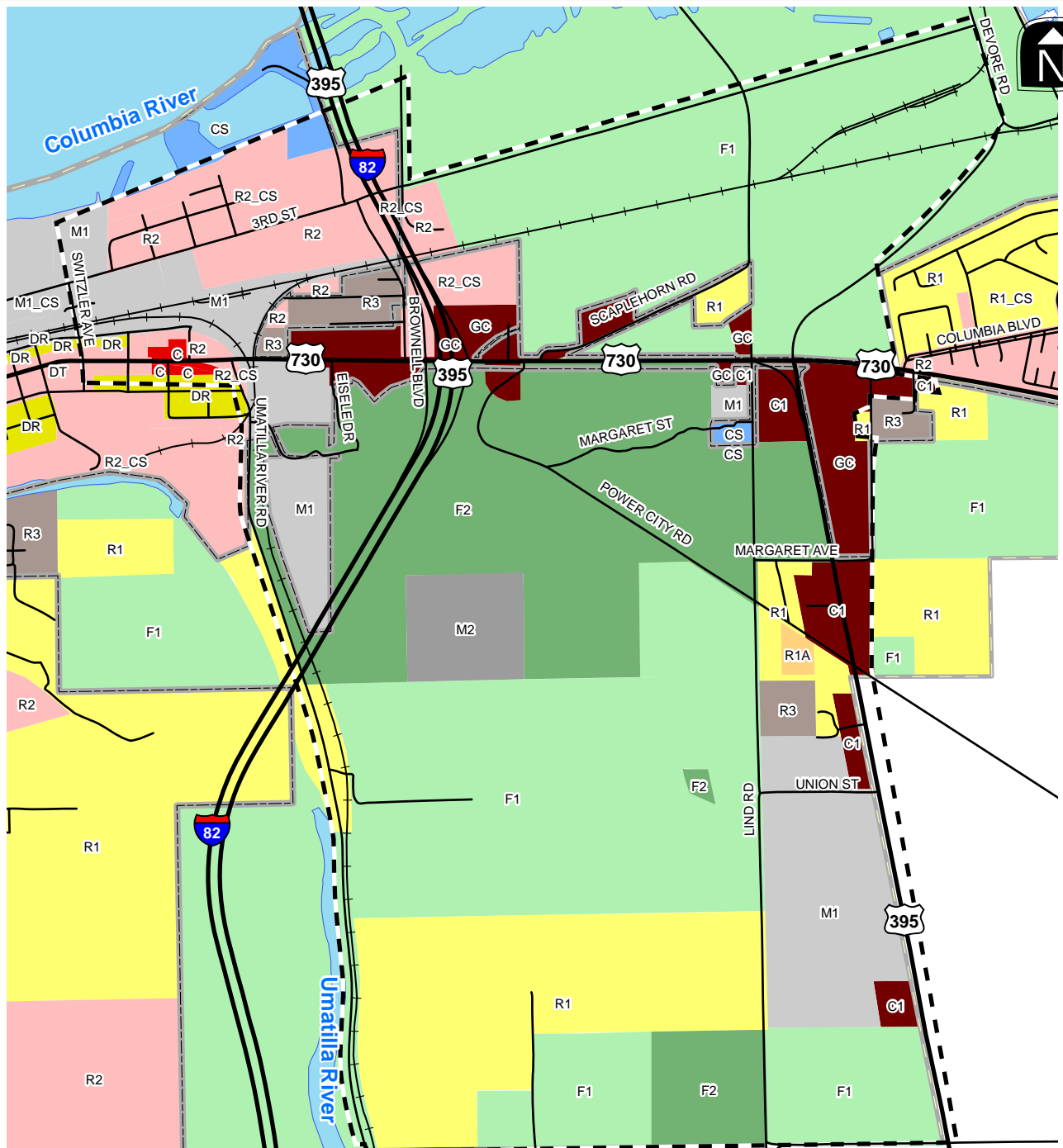

LEGEND

- Land Use Study Area
- Umatilla UGB
- Umatilla City Limits
- Zone**
- Commercial (C)
- Community Service (CS)
- Downtown Residential (DR)
- Downtown Transitional (DT)
- Exclusive Farm Use (F1)
- General Commercial (C1, GC)
- General Rural (F2)
- Heavy Industrial (M2)
- Light Industrial (M1)
- Residential, Multi-Family - Apartments (R3)
- Residential, Multi-Family (R2)
- Single Family Residential (R1)
- Two Acre Residential (R1A)

STUDY AREA ZONING UMATILLA, OREGON FIGURE

H:\profiles\110369 - I-82 US 730 IAMP\GIS\UmatillaZoningMap.mxd

General Rural (F2) - Land zoned F2 is so designated to maintain the “openness and rural nature of the country-side” and is applied to land not suited for EFU classification. The F2 zoning is intended to provide areas “appropriate for most kinds of typical rural development” and where the Planning Commission has the ability to attach special conditions (i.e., dimensional standards) to certain uses to minimize potentially detrimental effects on neighboring lands. Single-family dwelling units, as well as planned unit developments are permitted outright. The minimum lot size for the “principal dwelling unit” is 19 acres, with the Department of Environmental Quality determining all other lot sized based on public health. Other permitted uses include farm and forest product propagating, harvesting, and processing (using portable equipment for forest products), veterinary services, boarding houses, schools, churches, playgrounds, and golf courses. Conditional uses include airports, dog kennels, hog farms, landfills, livestock lots, asphalt plants, and mobile home parks.

Agricultural-Residential Zone (R-1) - This zone is intended to provide areas suitable for very low density residential along with the continuation of agricultural uses. Other uses permitted conditionally include commercial greenhouses and nurseries, nursing homes, and mobile home parks. Utilities are not anticipated to be available to these areas “in the foreseeable future.” Minimum lot area is four acres for residential uses; for non-residential uses the code states that minimum lot area will be determined by what is necessary “for the protection of public health,” as determined by the Department of Environmental Quality.

Two Acre Residential (R-1A) – The R-1A zone is intended to provide land for low density residential development within farming areas where City utilities are not anticipated “in the foreseeable future” and where conditions necessitate “spaced residential uses.” Two-acres is the minimum lot area for residential uses in this zone; minimum lot area for nonresidential uses is determined by the Department of Environmental Quality. In addition to single-family residential and farm uses, other uses permitted outright include noncommercial outdoor recreation, schools, noncommercial greenhouses and nurseries, and public or semi-public uses. Uses allowed conditionally include boarding houses, churches, mobile home parks, community centers, veterinary clinics, horse boarding stables, nursing and convalescence homes, and commercial nurseries.

General Commercial (C-1) - The C-1 zone district provides areas for rural retail and commercial services. A diversity of commercial uses are permitted, including eating and drinking establishments, banking institutions, hotel/motels, office buildings, sporting goods stores, automotive service stations, amusement parks, and greenhouses and nurseries. Conditional uses expand what is allowed in the C-1 to include such uses as mobile home parks, veterinarians, mini-warehouses, and welding shops. Minimum lot area is determined by the Department of Environmental Quality based on what is necessary to protect public health.

Light Industrial (M-1) - The County’s M-1 zone is intended to provide land for industrial uses which are compatible with nearby homes, businesses or farm operations. Locational criteria in the code also state that M-1 zoning is appropriate near major transportation facilities. A wide variety of industrial uses are permitted, including mini-warehouses, bottling, food products manufacturing (including meat processing and storage), machine shops, and the manufacturing, compounding, and assembling of products made from a specified list of prepared materials.

Conditional uses expand the list of uses that may be permitted in the M-1 zone to include some uses more commercial in nature (such as greenhouses and nurseries, commercial gravel pits, and eating and drinking establishments), support services (such as financial institutions and veterinarians), and any type of major industrial use if it meets threshold criteria (employs more than 200, has land needs of over 20 acres of land, or uses a given number of energy BTUs). Junkyards and wrecking yards are also permitted conditionally. Minimum lot area is determined by the Department of Environmental Quality based on what is necessary to protect public health.

Heavy Industrial (M-2) - The intent of the County M-2 zoning is to provide for areas where industrial development with “potential nuisances” will have a minimum negative effect on adjacent property. With a few limitations, all manner of manufacturing, repairing, compounding, fabricating, assembling, processing, treating and storage of products is permitted in this zone. Sand and gravel yards, welding, and materials storage is permitted. Conditional uses are similar to those allowed in the M-1 zone. Minimum lot area is determined by the Department of Environmental Quality based on what is necessary to protect public health.

12.3.411(2) City of Umatilla Zoning

The City of Umatilla’s Zoning Ordinance implements zoning “districts” to regulate land use (see Chapter 2, Plan Designations and Map, in Title 10). Chapters 2 through Chapter 5 of the Zoning Ordinance establish permitted uses and development standards for residential, commercial, and industrial zones. Below is an overview of these provisions for the zoning districts within the study area.

Single-Family Residential (R-1) - R-1 is the City’s low density, single-family residential zone. Besides single-family dwellings, family daycare providers and residential homes are permitted uses. Community services uses are permitted conditionally (see below for types of uses). The minimum lot area is 8,000 square feet and maximum building height is 35 feet.

Medium Density Residential (R-2) - R-2 zoning is intended for medium density (one dwelling per 3,500 square feet) residential uses. In addition to single-family detached houses, attached residences on smaller lots, two-family, and multi-family housing is permitted. Boarding houses, manufactured home parks, and limited office use (office or clinic for doctor, dentist or other practitioner of the healing arts, attorney, architect, engineer, surveyor or accountant) are permitted conditionally. Maximum residential density in this zone is one dwelling per three thousand five hundred (3,500) square feet; minimum lot area is 5,000 square feet and the height limit is 35 feet.

Multi-family Residential (R-3) - R-3 zoning permits residential housing types that include apartments, townhouses, and cluster developments at a density of one dwelling per two thousand (2,000) square feet. Family daycare providers, residential homes and residential facilities are also permitted outright. Conditional uses include boarding houses, community services (see below for types of uses), and professional offices, including medical, law, accountant, architect, and engineering. Minimum lot area in this zone is 5,000 square feet and the height limit is 35 feet.

Downtown Residential (DR) - The purpose of the downtown residential district is to accommodate higher density residential developments and office uses in the downtown area. Permitted housing types include attached housing, apartments, and townhouses. Existing single-family houses are permitted and may be improved. Expansion of existing commercial businesses is also permitted, with restrictions. Family daycare providers, residential homes, and residential facilities are permitted outright, as are professional offices (financial, business, medical/dental), with restrictions. Community services uses are permitted conditionally (see below for types of uses). For residential uses, the maximum allowable density is one dwelling unit per two thousand (2,000) square feet. For freestanding dwellings or structures the minimum lot area is 5,000 square feet; minimum lot area for attached structures is 2,000 square feet.

Downtown Commercial (DC) - The purpose of the downtown commercial district is to provide a concentrated central business district centered on 6th Street (US 730). This zone allows a mix of civic, retail, service, office and residential uses. Any commercial use is permitted, provided it is conducted wholly within an enclosed building, and residential uses are allowed above or behind ground-floor, street-frontage retail. Community services uses are permitted conditionally (see below for types of uses). There is no minimum lot area requirement and 100% building coverage is allowed. Residential uses are permitted at a density of one dwelling per two thousand (2,000) square feet (R-3 requirements).

General Commercial (C-1) - The stated purpose of the General Commercial District is to provide areas for a full range of commercial uses and, in particular, to accommodate uses which require large sites and high visibility. The Zoning Code directs that General Commercial areas should be located along major travel routes and at major intersections. Commercial uses that are both conducted wholly within an enclosed building, as well as those that require outdoor storage or display of products such as lumberyards, motor vehicle sales lots, and plant nurseries, are allowed. Beyond this description, a list of permitted uses is not provided. Automobile service stations, community services (see below and Zoning Ordinance Chapter 6) and recreational vehicle parks are called out as conditional uses. In addition to commercial uses, apartments are permitted in multi-storied buildings on the second floor or above, provided the ground floor is occupied by a commercial use. The minimum lot area requirement is 5,000 square feet and the maximum site coverage is 90 percent; there is no maximum lot area requirement. Building height is limited to 35 feet.

Downtown Transitional (DT) - Downtown commercial uses are permitted in this district and subject to the some standards and limitations. General commercial uses are permitted conditionally and are listed in Article D (Downtown Transitional) as including the following:

- a. Commercial uses that are not conducted wholly within an enclosed building, including a use that requires outdoor storage or display of products, such as lumberyards, motor vehicle sales lots, and plant nurseries.
- b. Commercial uses that are conducted wholly within an enclosed building.
- c. Temporary outside displays and promotional activities directly related and subordinate to the primary business.

d. Drive through windows for any use.

There is no minimum or maximum lot area requirement and the maximum site coverage is 100 percent. Building height is limited to 35 feet.

Light Industrial (M-1) - The M-1 district allows for a variety of industrial uses, including manufacturing, processing, packing, assembly, distribution, repair, finishing or refinishing, testing, fabrication, research and development, warehousing, and servicing activities. Minimum lot size is 5,000 square feet; maximum site coverage is 60%. Up to one hundred percent (100%) of the total floor area may consist of these manufacturing and distribution uses; storage area may not exceed fifty percent (50%) of the site. In addition to permitted uses listed above, Community Services are a conditional use in all the zones within the IMSA. As stated in the Zoning Ordinance, the CS designation provides “a procedure and standards for the review of special uses which, by reason of their public convenience, necessity, unusual character, technical need or effect on the neighborhood, may be appropriate in any district but not suitable for listing within the other sections of the code.”

12.3.420 Land Use Inventory

For purposes of describing existing zoning and land uses within the IMSA, the narrative below will consider each “quadrant” that is formed by the interchange and the study area boundary.

12.3.420(1) Northwest of the Interchange

The northwest quadrant of the IMSA extends north to the Columbia River and west to Switzler Avenue. The majority of the land in this quadrant is within the city limits. This area includes Community Service zoning on land owned by the Port of Umatilla. South from the Port there is an area zoned Downtown Transitional. Land surrounding Union Pacific Railroad’s “Umatilla Turn” is zoned Light Industrial. General Commercial lies north of US 730, west of the interchange.

Existing uses in the northwest quadrant include a combination of residential, recreation, and transportation-related uses. The ODOT Port of Entry weigh station directly northwest of the interchange is probably the most significant use in the quadrant. The facility takes access on US 730 at a distance that is less than spacing standards for interchange ramps and the nearest intersections. The sub-standard spacing is exacerbated by the heavy volume of large truck traffic using this access.

Older single-family homes are located directly north of the Port of Entry, a high retaining wall separating the two sets of uses. The railroad borders the other side of this cluster of homes. North of the railroad and 3rd Street, which parallel the Columbia River, is Port of Umatilla land with an RV camp and boat launch.

The area to the west and occupying the rest of the northwest quadrant is a mixture of predominantly low-density, single-family residential uses and multi-family residential uses, where buildings are in fair to poor condition. Amongst the residential uses and closer to US 730

are self-storage units, which are sometimes used as a way of reserving land for future development.

12.3.420(2) Northeast of the Interchange

Land in the northeast quadrant of the interchange is within the city's UGB and lies both within and outside of the current city limits. A large portion of this quadrant, west to Devore Road, is zoned EFU. The pockets of city land include General Commercial zoning in Sharps Corner, just northeast of the interchange, and along Scaplehorn Road and General Commercial zoning just west of US 395, north of 3rd Street and east of Brownell Boulevard.

The City's R-2 zoning lies north of Sharps Corner, between the railroad tracks and the commercial uses in the northeast quadrant of the interchange. Another residential area is accessed off of Scaplehorn Road and is zoned R-1.

Existing uses identified in a site visit consist mainly of public facilities or utilities and open space. There is a small cluster of single-family homes directly northeast of the interchange in Sharps Corner and along Scaplehorn Road to the east, the only areas of the northeast quadrant within the city limits. An irrigation ditch runs northeast/southwest under the interchange. Land in this quadrant slopes from US 730 down to the river. The McNary substation and an Army Corps of Engineers park and trails are found north of the railroad, leading up to the river. There is a large concentration of Bonneville Power Authority (BPA) electricity transmission lines north of US 730 in the central portion of the northeast quadrant.

12.3.420(3) Southwest of the Interchange

The area in the southwest quadrant of the study area is within the city's UGB and lies both within and outside of the current city limits. City zoning here includes Light Industrial and a small portion of General Commercial directly west of the interchange, on both sides of US 730. South of this commercial area and west of I-82 is General Rural County zoning.

There is a heavy concentration of highway- and motor vehicle-oriented commercial uses along US 730 west of the interchange. The Crossroads Lounge, gas station, convenience stores, and restaurants found here are largely oriented toward the freight truck traffic passing through the interchange and using the Port of Entry across US 730. A post office is also located amongst these uses, which is federally owned or leased.

The Union Pacific Railroad travels along the western edge of the study area in this quadrant, and a spur line passes under US 730 on the north side of the quadrant and under I-82 on the east side. Land along US 730 and east of the railroad spur line is within the city limits in the quadrant. The railroad spur line also parallels the Umatilla River and Umatilla River Road. The riverfront, wetlands, and woodland areas are predominant in this corridor with sparse residential uses, which are mostly manufactured single-family homes.

12.3.420(4) Southeast of the Interchange

The southeast quadrant contains the largest portion of the IMSA. This area east of the I-82/US 730 interchange is mostly vacant or underdeveloped and is almost entirely within Umatilla's

UGB. Land in the immediate vicinity of the US 730/US 395 intersection is included in this quadrant, and south of Power City Road, US 395 forms the eastern boundary of the IMSA, south to the city's UGB line.

This is the largest quadrant in the IMSA and it is mostly unincorporated, vacant land. On its eastern end, the quadrant includes part of the intersection of US 730 and US 395, Buck's Corner. Land directly south of US 730 slopes up from the highway, is vacant, and has a heavy concentration of transmission lines. The City is interested in the economic development potential of this area and intends to develop a local street network plan that supports the safe and efficient operations of the interchange and the US 730/US 395 intersection.

County zoning in this area includes General Commercial and Light Industrial uses at the intersection of US 730 and US 395. City General Commercial zoning is concentrated south of US 730, in a small parcel west of existing County commercial land. A small flag-lot of land zoned Community Service is also in this area. The unincorporated community of Power City lies to the east of US 395; Power City Road cuts diagonally through the southeast quadrant of the interchange, starting at US 730 and heading south to US 395.

Farmland and aggregate mining are the predominant uses in the southern portion of southeast quadrant. There are a few scattered homes closer to I-82 and a cluster of rural low-density single-family homes in the southeast corner of the quadrant. Transmission lines are massed directly south of US 730 in this quadrant branch and thin out in the southern portion of the quadrant.

12.3.430 Existing Transportation Inventory

The second major component of the I-82/US 730 IAMP existing conditions evaluation process is the transportation system. The existing transportation inventory provides a detailed description of all transportation facilities and travel modes within the IMSA. In addition, the inventory identifies the current operational, traffic control, and geometric characteristics of roadways and other transportation facilities.

12.3.431 Roadway Facilities

The roadways within the IMSA include state and city roadways. A description of each of the functionally classified roadway facilities is summarized in Table 12.3-1. *Figure 12.3-5* illustrates the existing lane configurations and traffic control devices at the respective study intersections

12.3.431(1) Interstate-82

Interstate 82 is a four-lane interstate highway that runs north-south through Umatilla. It connects I-84 in Oregon to I-90 in Washington and travels through Yakima and the Tri-Cities in Washington. I-82 is part of the National Highway System and is designated in the 1999 Oregon Highway Plan (Reference 1) as an Interstate Highway, Freight Route, and Truck Route.

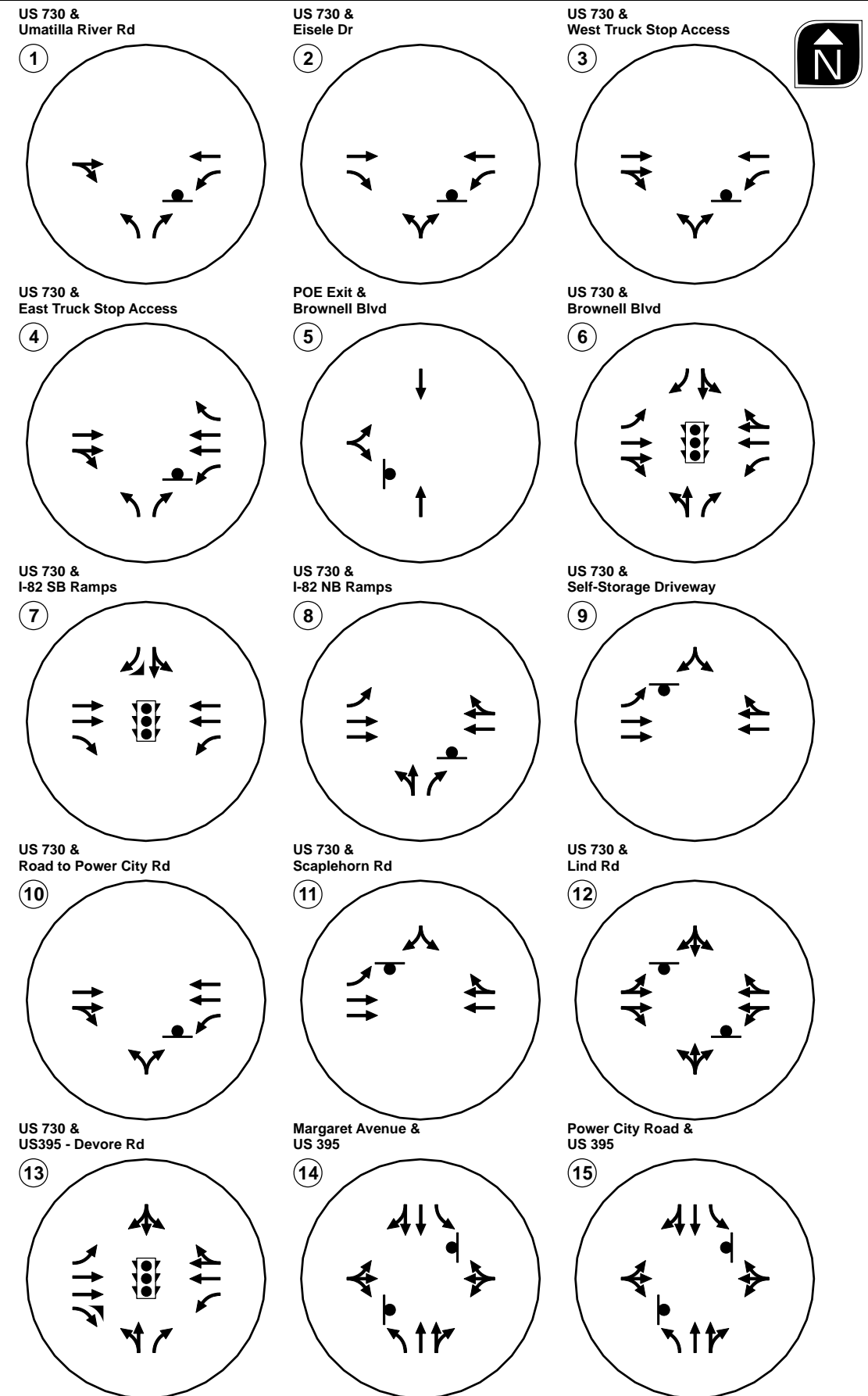

LEGEND

- STOP SIGN
- TRAFFIC SIGNAL

EXISTING LANE CONFIGURATIONS AND TRAFFIC CONTROL DEVICES UMATILLA, OREGON FIGURE

H:\p\profile\10369 - I-82 US 730 IAMP\GIS\Ex.LaneConfig2.mxd

12.3.431(2) Interstate-82/US 730 Interchange Ramps

The I-82/US-730 interchange ramps are configured in a diamond interchange form. The southbound ramp terminal is signalized, while the northbound ramp terminal is stop-controlled on the off-ramp approach. Due to the area’s topography, I-82 is elevated over US 730. South of US 730, I-82 has an uphill grade from north to south. Consequently, vehicles, many of which are trucks, entering I-82 southbound must travel up a grade while accelerating to merge onto I-82.

Table 12.3-1 EXISTING TRANSPORTATION FACILITIES AND ROADWAY DESIGNATIONS

Roadway	Existing Roadway Ownership/ Functional Classification ¹	Cross-section	Posted Speed (mph)	Side-walks?	Bicycle Lanes?	On-Street Parking?
Interstate-82	ODOT/ Interstate Highway	4-lane	65	No	No	No
US 730 (6th Street)	ODOT/ Statewide/Regional Highway-Freight Routes ³ -STA-UBA ²	4/5-lane	45/35/25	Partial	Shoulder s	No
US 395	ODOT/ Statewide Highway – Freight Route ³	4/5-lane	55	No	Shoulder s	No
Umatilla River Road	County/Minor Arterial	2-lane	25/30	Partial	No	No
Brownell Boulevard	County/ Minor Arterial	2-lane	None	No	No	Yes
Power City Road	County/Minor Arterial – Collector ⁴	2-lane	None	No	No	No
Scaplehorn Road	County/Collector	2-lane	None	No	No	No
Lind Road	County/Minor Arterial-Collector-Local Street ⁵	2-lane	None	No	No	No
Devore Road	City/Collector	2-lane	25	No	No	No
Margaret Avenue	County/Minor Arterial	2-lane	None	No	No	No
Eisele Drive	City/Local	2-lane	None	No	No	No

¹ County-owned roadways within the City of Umatilla’s Urban Growth Boundary retain the City’s functional classification.

² US 730 is classified as a regional highway west of the I-82 ramps and a statewide highway from the SB I-82 ramp to US 395. The STA designation applies west of Sloan Avenue, the UBA designation applies from Sloan Avenue to Brownell Boulevard, and the Freight Route designation applies from US 395 to the NB I-82 ramp.

³ As Freight Routes, US 730 and US 395 are subject to the provisions of ORS 366.215 which states that Oregon “may not permanently reduce the vehicle-carrying capacity of an identified freight route when altering, relocating, changing or realigning a state highway unless safety or access considerations require the reduction.”

⁴ Power City Road is classified as a collector from west of Lind Road and a minor arterial from Lind Road to US 395.

⁵ Lind Road is classified as a minor arterial south of Margaret Avenue, a collector north of Margaret Avenue to the canal, and a local street north of the canal to US 730.

Operations at the southbound ramp terminals intersection with US 730 are directly influenced by nearby intersections. Exhibit 12.3-1, displayed below, shows the spacing between the I-82 ramp terminals and the neighboring intersections. As the exhibit shows, the signalized US 730/Brownell Boulevard intersection is located approximately 170 feet west of the southbound ramp terminal. Furthermore, the entrance to the Umatilla Port of Entry (POE) is

located only 150 feet west of the Brownell Boulevard intersection. Spacing this close presents the opportunity for vehicular queues to spillback from one intersection into the other intersection(s). While the POE entrance is not signalized at US 730, its flow is controlled by the internal weigh station, which can cause queues to back-up during peak periods. A significant portion of the traffic volume in the outer lanes of US 730 in both directions between the southbound ramp terminal and Brownell Boulevard is made up of heavy trucks traveling between I-82 southbound and the POE.

Exhibit 12.3-1 Intersection Spacing Near I-82 SB Ramp Terminals



12.3.431(3) US 730 (6th Street)

US 730, the Columbia River Highway, is classified by the Oregon Highway Plan as a Statewide Highway from the southbound I-82 ramp terminal east to US 395. West of the southbound terminal, it is classified as a Regional Highway and is not a National Highway System (NHS) route. Between the I-82 northbound ramp and US 395, it is designated as a Freight Route and a Truck Route. It travels primarily east-west along the Columbia River from I-84 east of Boardman to US 12 in Washington, passing through Irrigon and Umatilla along the way. Locally, it is also known as 6th Street through Umatilla. 3rd Street and US 730 provide the only east-west connections between downtown Umatilla and the McNary area of Umatilla, making US 730 a vital connection to Umatilla. Within the study area, US 730 has signalized intersections at the southbound I-82 ramp terminal, Brownell Boulevard, and US 395.

12.3.431(4) US 395

US 395, the Umatilla-Stanfield Highway, is classified as a Statewide Highway by the Oregon Highway Plan. It is also a designated Freight Route and Truck Route. This highway provides a connection between US 730, the cities of Hermiston and Stanfield, and I-84.

12.3.431(5) Umatilla River Road

Umatilla River Road is a County roadway that runs along the Umatilla River and provides a connection between US 730 and Hermiston, essentially serving as a parallel route to US 395 through this area. It is a two-lane roadway with narrow shoulders that are partially paved and partially gravel. There are a handful of residential and farm properties that connect to Umatilla

River Road. It is classified as a minor arterial by the City of Umatilla Transportation System Plan (TSP, Reference 2). The TSP notes that this roadway is the first choice for many residents traveling between Umatilla and Hermiston.

12.3.431(6) Brownell Boulevard

Brownell Boulevard is a two-lane County roadway connecting US 730 to 3rd Street on the west side of I-82. East of I-82 (the roadway was divided due to the construction of I-82), Brownell Boulevard continues north from 3rd Street to a wildlife refuge on the Columbia River shore. All traffic from the Umatilla Port of Entry exits the facility onto Brownell Boulevard before returning to US 730 and I-82. It is classified as a minor arterial. On-street parking is permitted on Brownell Boulevard.

12.3.431(7) Power City Road

Power City Road provides access to the gravel quarries in the southeast quadrant of the I-82/US 730 interchange and to residential areas west of US 395. Access to US 730 is provided via a private driveway between I-82 and Scaplehorn Road. Power City Road is a two-lane roadway and is classified as a minor arterial east of Lind Road to US 395 and as a collector west of Lind Road. The roadway is not paved west of Lind Road.

12.3.431(8) Scaplehorn Road

Scaplehorn Road is a two-lane County roadway that provides access to several home sites and a number of undeveloped parcels that have the potential for commercial development. Scaplehorn Road is classified as a collector.

12.3.431(9) Lind Road

Lind Road parallels US 395 from US 730 to Bensel Road, which is located at the southern boundary of the IMSA. Lind Road is two-lane County roadway classified as a minor arterial from Bensel Road to Margaret Avenue, a collector from Margaret Avenue to the irrigation canal, and then as a local street from the canal to US 730.

12.3.431(10) Devore Road

Devore Road is a two-lane City roadway and is the northern approach of the US 730/US 395 intersection. Devore Road is a collector and provides access to 3rd Street and the McNary Dam.

12.3.431(11) Margaret Avenue

Margaret Avenue provides access to residential properties on the west side of US 395. It is two-lane roadway and is classified as a minor arterial.

12.3.431(12) Eisele Drive

Eisele Drive is a two-lane City roadway. It provides access to commercial properties and the Post Office south of US 730. Eisele Drive is also sometimes referred to as Draper Street.

12.3.432 Public Transportation Facilities

There are no fixed line public transportation facilities that operate within the IMSA. Regional dial-a-ride providers, such as RSVP of Eastern Oregon, provide limited service for elderly and/or disabled Umatilla residents. These providers are located outside of Umatilla. Intercity bus service is provided by Greyhound. Daily service is provided at a stop located at the US 730/Switzler Avenue intersection on an as-needed basis, meaning passengers waiting at the stop must flag-down the bus. There is no shelter or obvious markings at the stop location. The service provides connections to Portland and Pendleton, Oregon, and Tri-Cities, Washington.

12.3.433 Pedestrian and Bicycle Facilities

Sidewalks and shoulders make up the exclusive pedestrian and bicycle facilities inventory along the study roadways. Sidewalks are present on both sides of US 730 west of the Umatilla River and on the south side only from the bridge over the river to Brownell Boulevard. There is also a sidewalk on the west side of Umatilla River Road between US 730 and 7th Street. Generally, pedestrian activity in the study area is the highest on US 730 between the Umatilla River and Brownell Boulevard (it should be noted that pedestrian counts were not conducted on US 395 except at its intersection with US 730). The western driveway from the truck stop onto US 730 had the highest amount of pedestrian activity, with 27 pedestrians walking through the intersection from 6 a.m. to 10 p.m. The highest hour occurred from 2:00 to 3:00 p.m. when 6 pedestrians were observed.

Marked bicycle lanes are not present on any of the study roadways. Shoulders are provided along the majority of US 730 and US 395, as well as sections of Umatilla River Road and Devore Road, though they are often either narrow or gravel. The highest bicycle volumes were observed at the US 730/Brownell Boulevard intersection, where 12 bicycles passed through between 6 a.m. and 10 p.m. Six bicycles passed through US 730/Lind Road and the Port of Entry exit onto Brownell Boulevard as well. No bicycles were observed along US 395, during the count months.

12.3.440 Existing Traffic Volumes and Peak Hour Operations

Manual intersection turning movement counts were obtained from ODOT at each of the study intersections to assess the operational performance and characteristics within the study area. These counts were conducted on mid-week days in June and September 2009, as well as January 2010. A description of the analysis conducted with this data is summarized in the following sections.

12.3.441 Peak Hour Intersection Volumes

Turning movement counts at each intersection were recorded from 6:00 a.m. to 10:00 p.m. Because of the close proximity of the intersections, a system-wide peak hour is identified based on the volumes at all study intersections. The weekday p.m. peak hour in the IMSA occurs from 4:30–5:30 p.m. The turning movement volumes at each study intersection are balanced during this hour to account for the differences in data collection dates and locations where some data is missing.

12.3.441(1) Seasonal Adjustments

Following the methodology outlined by ODOT's Analysis Procedures Manual (APM, Reference 3), a seasonal adjustment factor was applied to the traffic counts collected for the existing conditions analysis in order to estimate 30th highest hour volumes. The counts were collected in June, September, and January, so seasonal adjustment factors were calculated for all three months. An exception to this is that volumes for I-82 were taken from ODOT automatic traffic recorder (ATR) #30-025, 0.58 mile south of the Washington border. These volumes are from the month of August, so no seasonal adjustment was necessary. There is not an ATR on a section of US 730 or US 395 in the vicinity of the study area that exhibits similar characteristics to the highways within the study area. In consultation with ODOT staff, ATR #05-006, located at milepost 53.33 on US 30 near Rainier, was determined to have the most similar characteristics to US 730 within the study area. The factors for US 730 and US 395 for June and September are 1.08, while the factor for January is 1.39. To ensure that these factors adequately represent the peak harvest period traffic volumes experienced in this area, they were compared to factors calculated from nearby ATR #30-025 on I-82. This comparison showed that the factors calculated from the US 30 ATR are similar to those that would be calculated from the I-82 ATR. Generally factors greater than 1.30 are to be avoided according to the APM; however, in this instance the January counts are balanced against neighboring June and September counts (e.g. if a seasonally adjusted January count is different than a seasonally adjusted June or September count, then the January count is corrected). Furthermore, the exiting volume from the Port of Entry was verified with Port of Entry staff to ensure it accurately reflects a peak volume experienced during the peak season.

Exhibits 12.3-2 through 12.3-4 illustrate the 16-hour volume peaking characteristics of the I-82 ramp traffic and I-82 through traffic. Exhibits 12.3-5 and 12.3-6 illustrate the 16-hour volume peaking characteristics of US 730 on either side of I-82. The volumes shown in these exhibits have been seasonally adjusted.

Traffic traveling to and from I-82 significantly influences traffic volumes on US 730. As the exhibits show, the peak hour volumes on each of the I-82 ramps are approximately 40-50% of the volumes on US 730 during that same period. Essentially, nearly half of the traffic on US 730 in the proximity of I-82 is traveling to or from the interstate.

Exhibits 12.3-2 and 12.3-3 show that the I-82 ramps each have a dominant traffic pattern that lasts throughout the day. Traffic volumes on the I-82 southbound off-ramp are significantly higher than volumes on the southbound on-ramp throughout the 16-hour period that counts were conducted. The exact reverse pattern occurs on the northbound ramps, where the off-ramp has significantly lower volumes than the on-ramp. These patterns are indicative of the region-wide, and even statewide, travel that is served by US 730 and US 395. Southbound traffic on I-82 that exits at this interchanges utilizes US 730 and US 395 to reach other regional (e.g. Hermiston and Irrigon) and statewide (e.g. I-84) destinations. Traffic entering northbound I-82 at this interchange reaches the interchange in a reverse pattern along these same routes.

Exhibit 12.3-2 Daily Traffic Volume Profile for I-82 Southbound Ramps at US 730

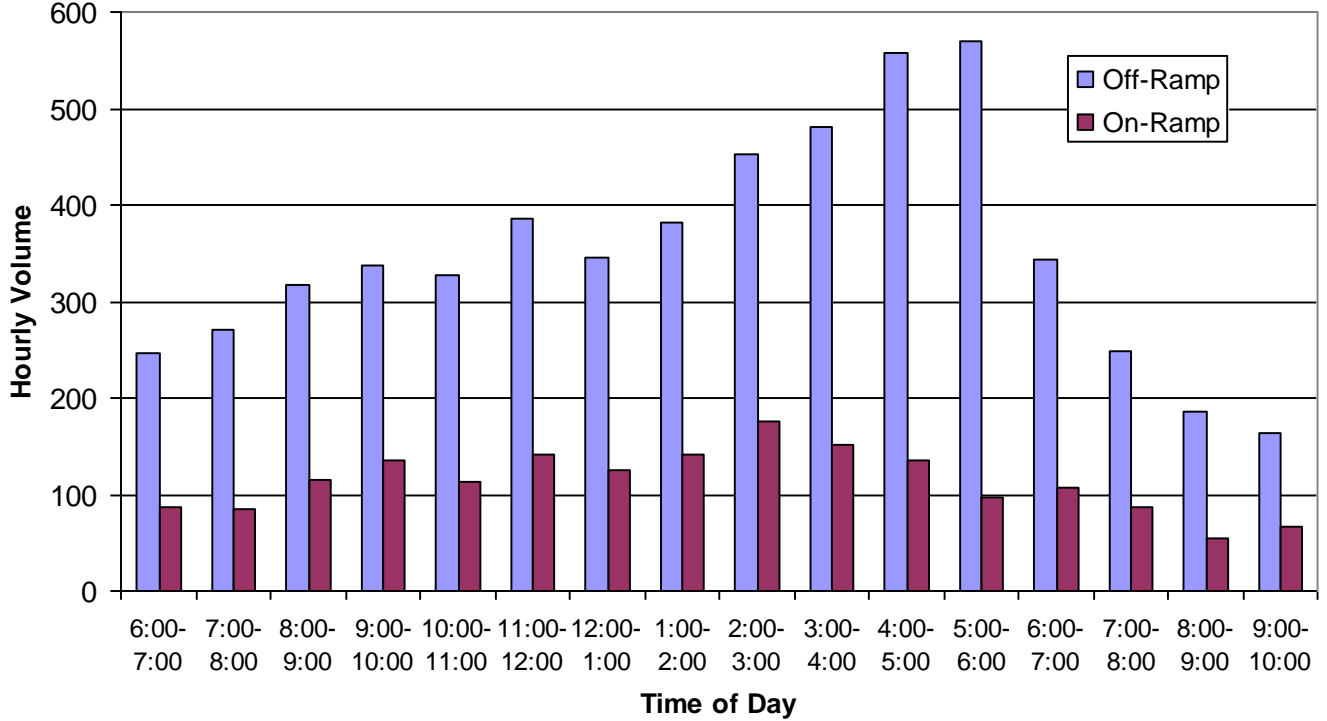

Exhibit 12.3-3 Daily Traffic Volume Profile for I-82 Northbound Ramps at US 730

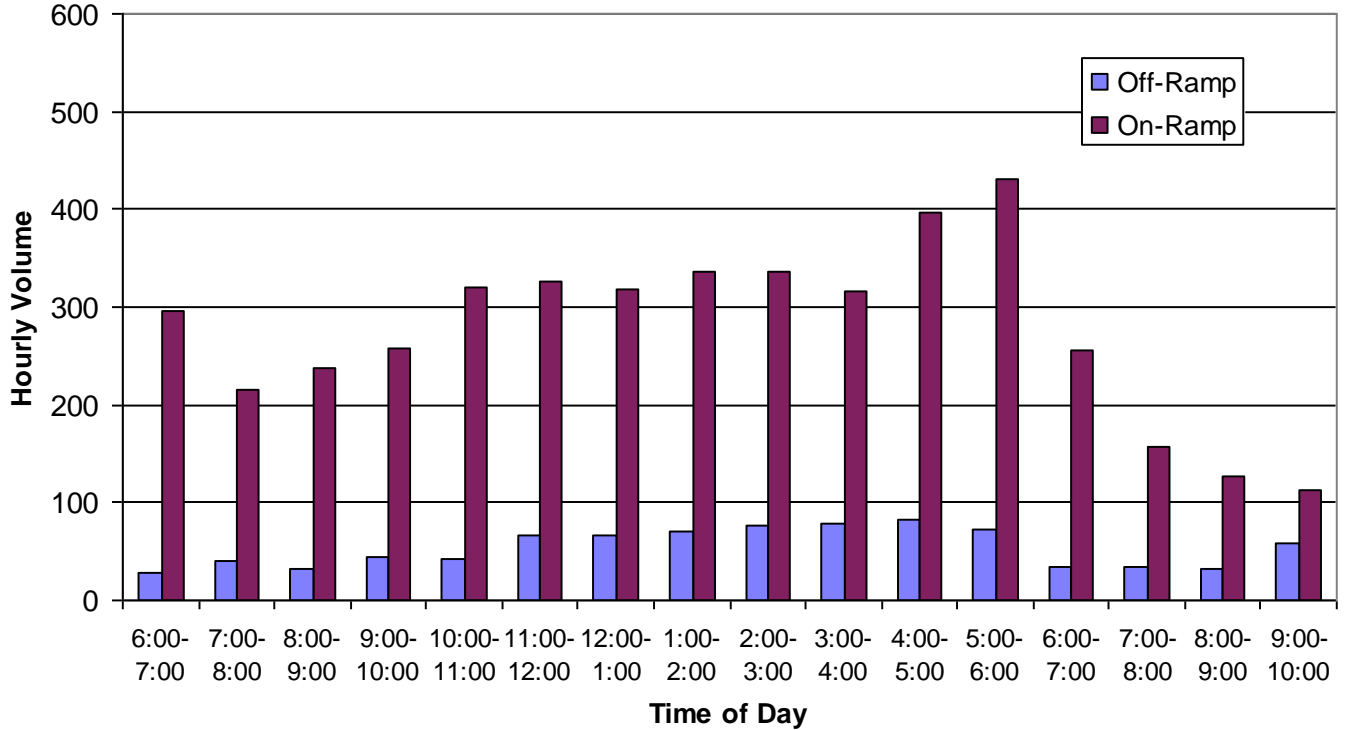

Exhibit 12.3-4 Daily Traffic Volume Profile for I-82 North of US 730

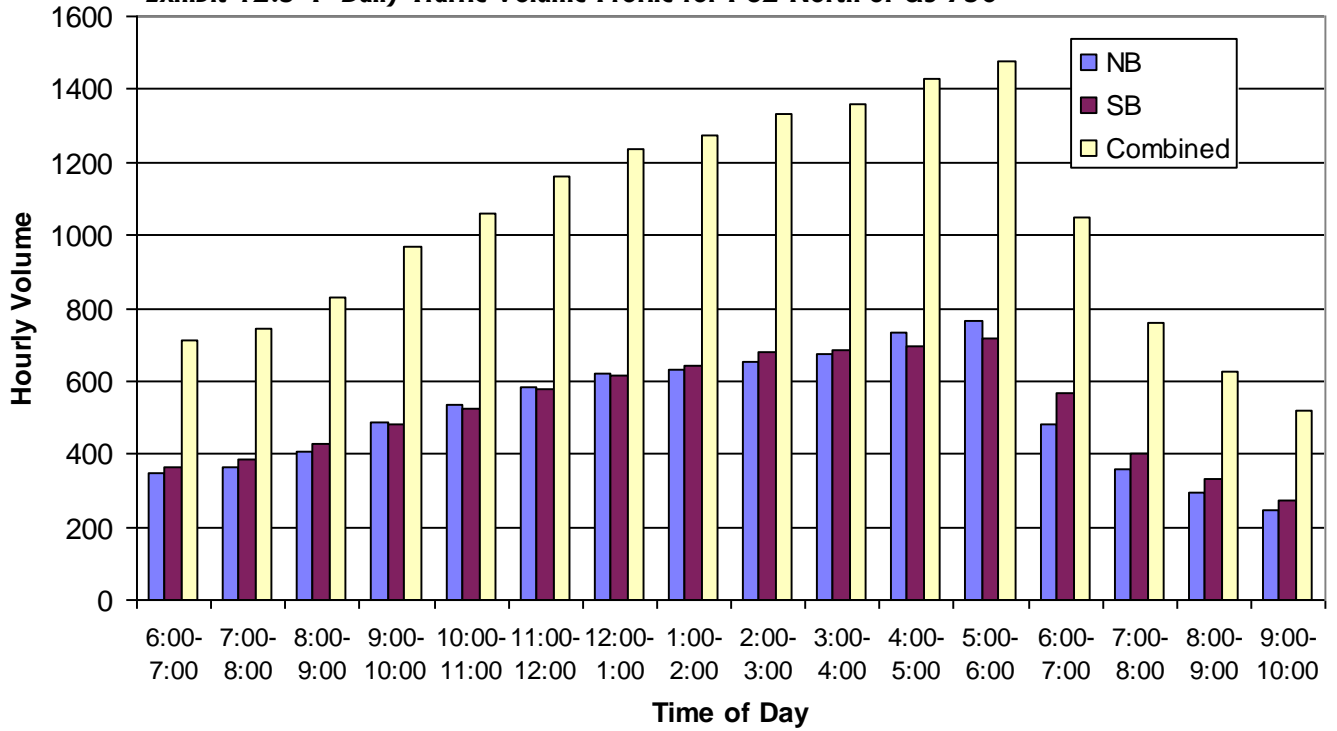
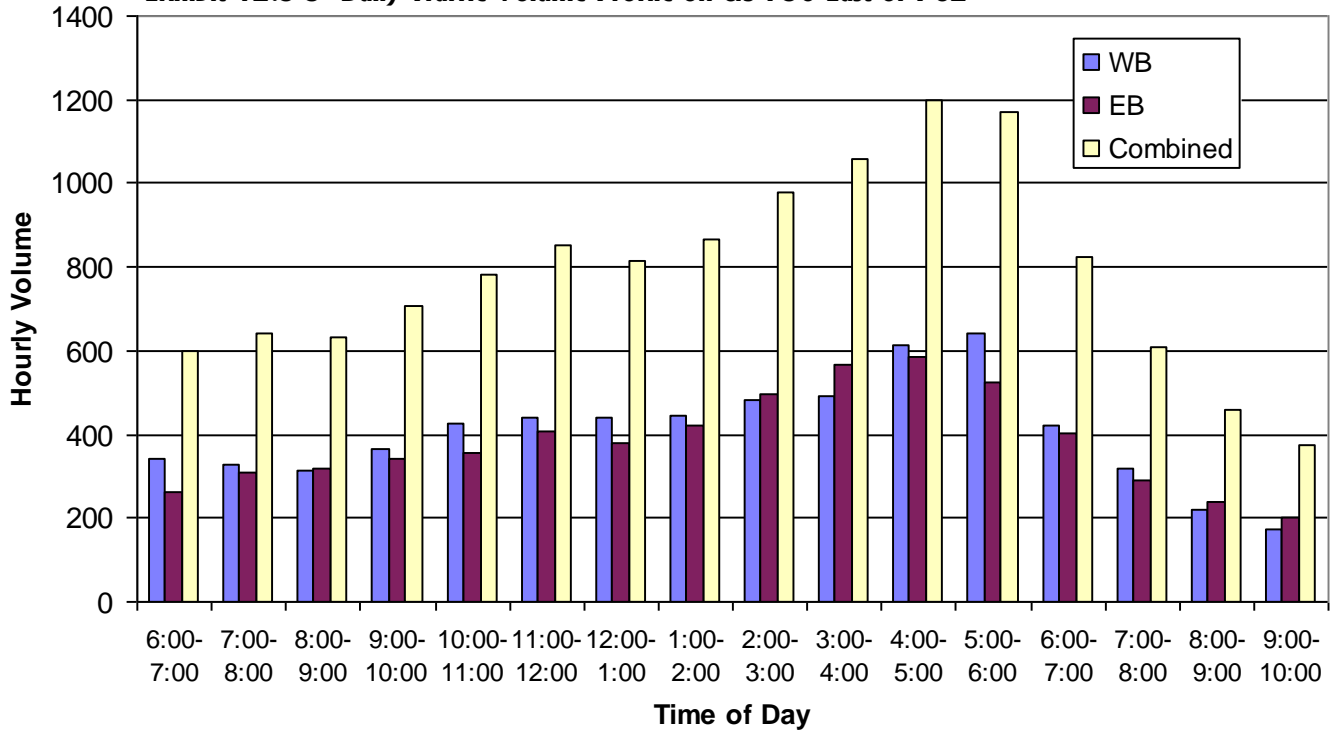
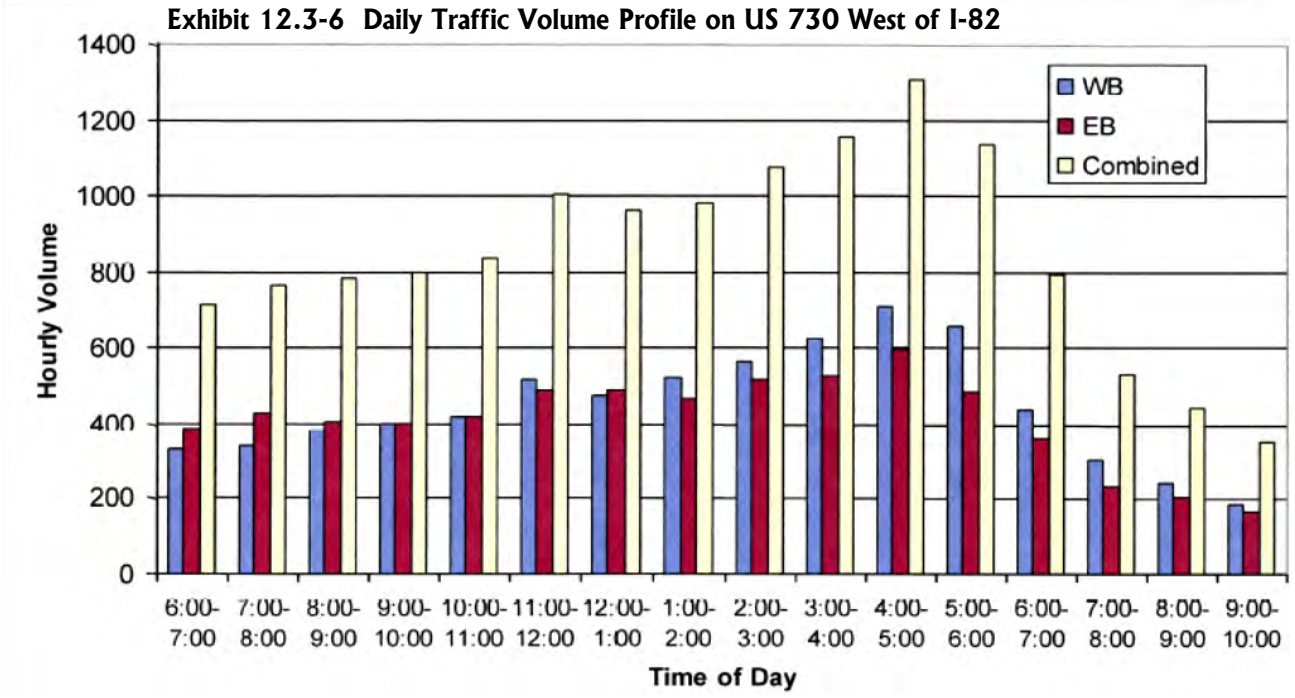
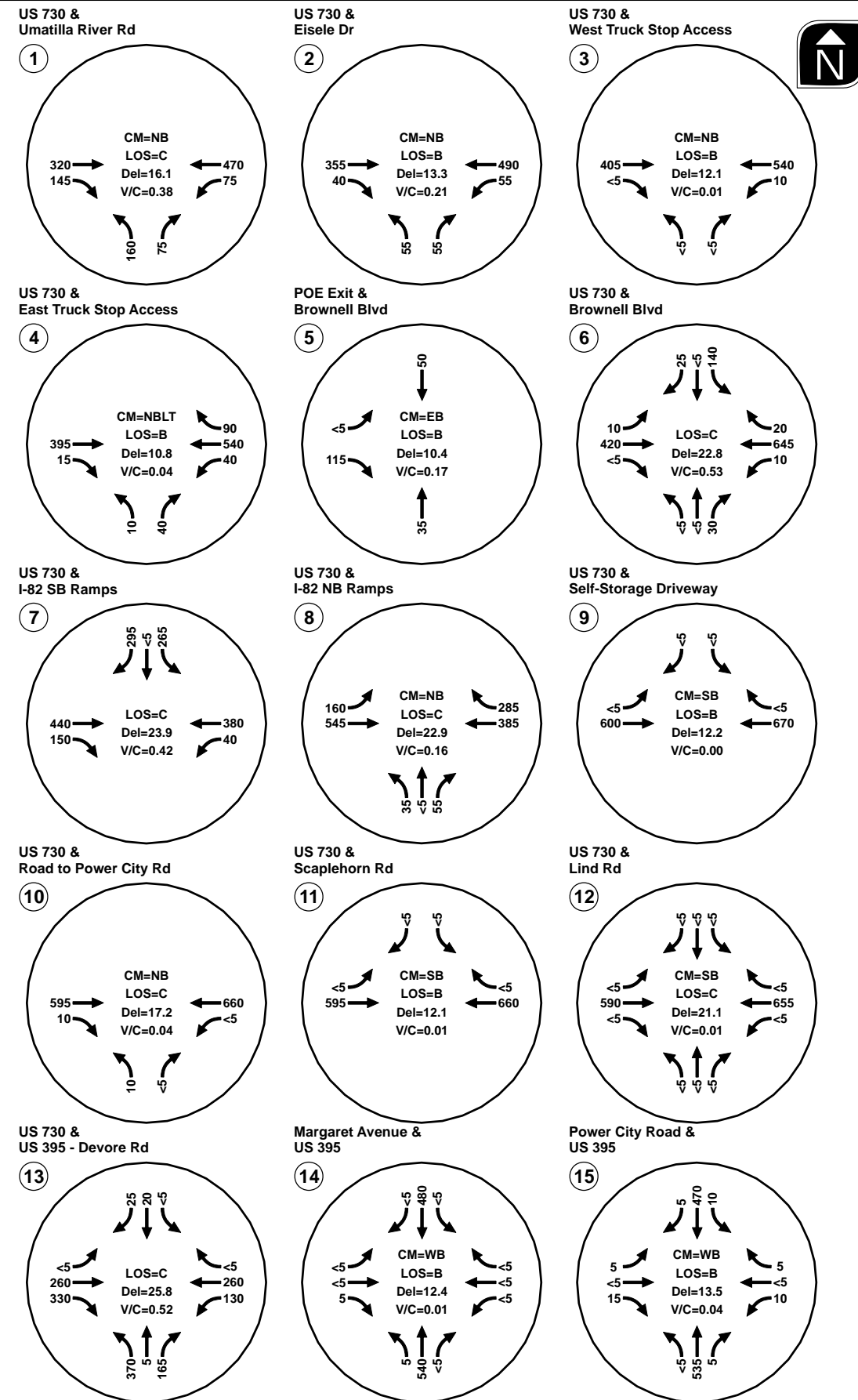
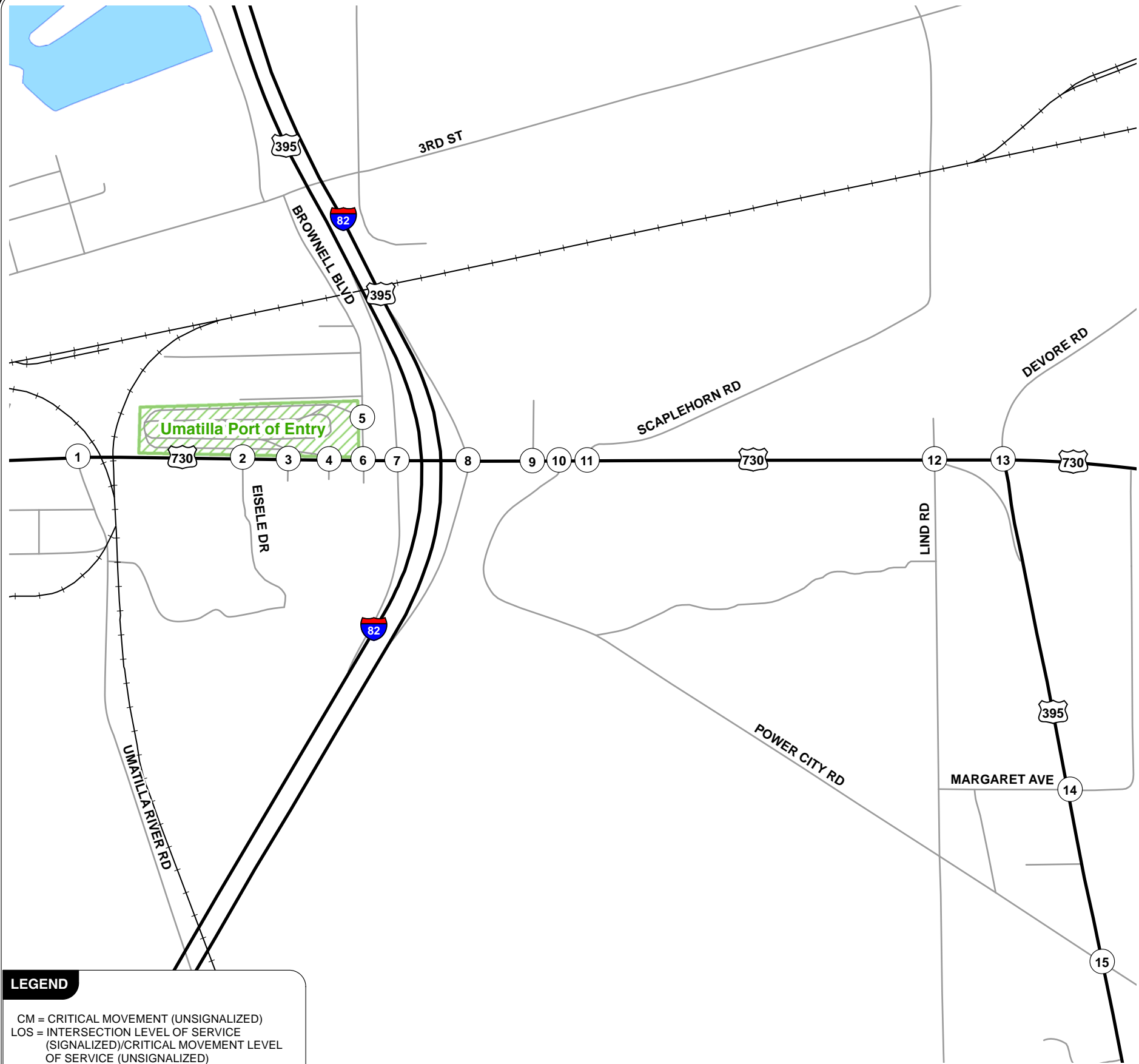

Exhibit 12.3-5 Daily Traffic Volume Profile on US 730 East of I-82





The weekday 30th highest hour intersection turning movement counts used for the existing conditions analysis are shown in *Figure 12.3-6*.



LEGEND

CM = CRITICAL MOVEMENT (UNSIGNALIZED)
 LOS = INTERSECTION LEVEL OF SERVICE (SIGNALIZED)/CRITICAL MOVEMENT LEVEL OF SERVICE (UNSIGNALIZED)
 Del = INTERSECTION AVERAGE CONTROL DELAY (SIGNALIZED)/CRITICAL MOVEMENT CONTROL DELAY (UNSIGNALIZED)
 V/C = CRITICAL VOLUME-TO-CAPACITY RATIO

**EXISTING TRAFFIC CONDITIONS
 30TH HIGHEST HOUR
 UMATILLA, OREGON** FIGURE

H:\p\proj\10369 - I-82 US 730 IAMP\GIS\ExOps2.mxd

12.3.442 Existing Intersection Operations

All level of service analyses described in this analysis was performed in accordance with the procedures stated in the 2000 *Highway Capacity Manual* (Reference 4). The OHP sets operational standards based on volume-to-capacity (v/c) ratios for the interchange ramp terminals (v/c of 0.80 for the northbound ramp terminal and 0.85 for the southbound ramp terminal), intersections of US 730 (v/c of 0.85 between Brownell Boulevard and Sloan Avenue and v/c of 0.70 east of I-82), and US 395 (v/c of 0.70). These standards apply to the overall v/c ratio at the signalized intersections and to the state highway approaches at unsignalized intersections. The minor street approaches that are stop-controlled at signalized intersections have a standard of a v/c ratio of 0.90.

As shown in *Figure 12.3-6*, all study intersections currently meet applicable operation standards when evaluated in isolation. The existing conditions operations worksheets are provided in the *Technical Appendix*. While overall intersection standards are met, there are operational and queuing concerns associated with the closely spaced signalized intersections on US 730 at Brownell Boulevard and the I-82 Southbound ramp terminal.

12.3.442(1) Brownell Boulevard and I-82 Southbound Ramp Terminal Intersections

The US 730 signalized intersections of Brownell Boulevard and the US 730/I-82 Southbound ramp terminal are located within close proximity, with approximately 170 feet between them (only approximately 110 feet between the southbound right-turn from the I-82 ramp to Brownell Boulevard). The signals have been coordinated and operate using the same controller as one signal in an effort to improve intersection operations. Nevertheless, queuing problems associated with truck traffic accessing the Umatilla Port of Entry weigh station continue to occur at the two intersections. This condition varies by season due to increase of trucks during mid-summer and fall harvests. During these times, it is not uncommon for sudden spikes in truck traffic to cause significant queuing from the Port of Entry station back onto US 730 and further back onto the Interstate 82 SB off-ramp. These situations force the Port of Entry staff to close down their weigh scales for a short period in order for the back-up to dissipate. Additionally, many of these trucks exit the Port of Entry and return to I-82 SB (see Exhibit 12.3-7). Only a few trucks are able to make the maneuver from Brownell Boulevard onto I-82 SB per signal cycle; therefore, queues on Brownell Boulevard back up to the Port of Entry exit during these peak times.

Exhibit 12.3-7 Trucks Exiting the Port of Entry to Return to I-82 Southbound



12.3.442(2) Weigh-in-Motion

As was mentioned above, commercial truck traffic exiting I-82 to be weighed at the POE influences traffic operations in the interchange vicinity. Commercial truck traffic must be weighed when entering Oregon from another state. Historically, this has primarily occurred at weigh stations, which has required trucks to exit the mainline of the highway in order to be weighed. For trucks entering Oregon from Washington via I-82, this has occurred at the Umatilla POE. This process adds to the time it takes to transport goods, and in the case of Umatilla, contributes heavy truck traffic to the non-Interstate system. In order to facilitate this process and reduce its impacts, ODOT implemented the Oregon Green Light program in 1997. This program allows commercial truck drivers that register with the program and install the supplied transponder to weigh-in-motion on the roadway and bypass the off-system weigh station. Such a bypass exists on I-82 at Umatilla, which reduces the amount of truck traffic utilizing the POE. In September 2009, approximately 30,700 trucks were weighed at Umatilla, with approximately 14,300 trucks, or approximately 47% of all trucks, being granted a bypass by the Green Light system. These are trucks that would have otherwise had to stop at the Umatilla POE. Statewide, the use of the Oregon Green Light program is steadily increasing, with the number of trucks being granted bypasses increasing by nearly 20% from 2006 to 2009. ODOT staff expect use of the program to continue to rise until the industry is saturated.

12.3.443 Traffic Safety

The crash histories at the study area intersections and along the study area highways (i.e. I-82, US 730, and US 395) were reviewed in an effort to identify potential safety issues. Crash records were obtained from ODOT for the five-year period from January 1, 2004 through December 31, 2008. Table 12.3-2 contains the summary of reported crashes at these intersections and Table 12.3-3 contains the summary of reported crashes along the roadways.

Table 12.3-2 Intersection Crash Histories (January 1, 2004 through December 31, 2008)

Intersection	# of Crashes	Crash Rate ¹	Crash Type				Severity		
			Angle	Rear-End	Turning	Other	PDO	Injury	Fatality
I-82 SB Ramp Terminal/ US 730	11	0.3	2	8	0	1	10	1	0
I-82 NB Ramp Terminal/ US 730	2	0.1	2	0	0	0	0	2	0
Umatilla River Rd/ US 730	3	0.1	1	0	0	1	2	1	0
Eisele Dr/US 730	1	0.1	0	0	0	1	0	1	0
West Truck Stop Access/US 730	None Reported								
East Truck Stop Access/US 730	None Reported								
Brownell Blvd/US 730	8	0.3	1	5	1	1	4	4	0
Self Storage Driveway/US 730	None Reported								
Road to Power City Road/US 730	None Reported								
Scaplehorn Rd/US 730	None Reported								
Lind Rd/US 730	None Reported								
US 395-Devore Rd/ US 730	11	0.4	5	3	2	1	7	4	0
Margaret Ave/US 395	None Reported								
Power City Rd/US 395	2	0.1	0	0	1	1	1	1	0

¹Crash rate is expressed in terms of crashes per million entering vehicles

Table 12.3-3 Roadway Segment Crash Histories (January 1, 2004 through December 31, 2008)

Roadway	# of Crashes	Crash Rate ¹	Crash Type					Severity		
			Angle/ Turning	Rear-End	Sideswipe	Fixed Object	Other	PDO	Injury	Fatality
I-82: WA State Line –Umatilla River Bridge	23	0.37	1	0	1	13	8	10	12	1
US 730: Sloan Ave – Columbia Blvd	46	1.32	14	23	4	1	4	29	17	0
US 395: US 730 – Union St	15	0.76	4	4	1	3	3	11	4	0

¹Crash rate is expressed in terms of crashes per million entering vehicles

The US 395-Devore Rd/US 730 intersection exhibits the highest crash rate in Table 12.3-2. Seven of the eleven reported crashes are angle or turning crashes. The majority of these seven crashes involve the southern US 395 approach. This approach is controlled using split-phasing, so no other movements on the other approaches at the intersection are permitted during the same phase. Field observations did not reveal any notable sight distance deficiencies. A more detailed

review of the crash data at this intersection did not reveal any weather-related or time of day patterns. That the southern US 395 approach is involved in the majority of the turning and angle crashes reported at this intersection is consistent with the higher traffic volumes and higher speeds on US 395.

The US 730/I-82 Southbound ramp terminal also had 11 reported crashes. The predominant crash pattern at this intersection is rear-end crashes. Five of the rear-end crashes occurred on the westbound approach, while the other three occurred on the southbound off-ramp. These patterns are fairly typical at signalized intersections, especially where traffic on certain approaches has been traveling uncontrolled for some distance (e.g. on I-82 or US 730 between US 395 and I-82). It is also worth noting that the I-82 bridge over US 730 obstructs the view of the traffic signal heads at this intersection for westbound traffic. Motorists traveling westbound on US 730 are generally not able to see the signal heads until US 730 begins to flatten just east of the northbound ramp terminals. This may be a contributing factor to rear-end crashes on the westbound approach.

Vehicular queues on the westbound approach at the US 730/I-82 Southbound ramp terminal do sometimes back up in front of the northbound ramp terminals during peak periods. The crash data at this intersection does not indicate that this is currently causing a significant number of crashes. However, this may become more of a safety issue as traffic volumes increase, and in turn, so do these instances of blockage.

As Table 12.3-3 shows, US 730 has the highest crash rate of the roadway segments within the study area. This is likely due to the greater presence of signalized intersections and driveways on this roadway compared to other two roadways. Rear-end and angle/turning crashes are the most common crash type along US 730, and the majority of these crashes were reported at one of the three signalized intersections. The fatality crash on I-82 occurred when the driver of a passenger car traveling northbound overturned. According to the crash report, the driver was traveling too fast for conditions, over-corrected, and skidded off the road. Pavement conditions were dry at the time, though it was at night. No other vehicles were involved in this crash.

12.3.450 Existing Roadway Access Conditions

Along the US 730 study corridor, there is no existing access control. There are currently 21 public and private access points (excluding the interchange ramp terminals) located within the US 730 Operations and Access Study Area (roughly ½ mile to the east and west of the interchange). Of these access points, 8 are located west of the interchange, while the remaining 13 access points are located east of the interchange. Access is somewhat limited on the west side by the presence of the Umatilla River, the Umatilla Port of Entry, which occupies the entire northern frontage along US 730 between Brownell Boulevard and the river, and the railroad tracks. *Figures 12.3-7 and 12.3-8* illustrate the location and type (public or private) of each of the access locations within the Operations and Access Study Area. Table 12.3-4 summarizes the tax lots and existing businesses served by each of the access points as well as other miscellaneous descriptive information such as driveway width, mile point location, and permit number (if applicable).

Oregon Administrative Rule 734, Division 51 and the Oregon Highway Plan (OHP) identify ODOT's access management standards within the vicinity of interchanges. Based on an outright application of the standards, no full public or private access is allowed within 1,320 feet (¼ mile) from the ramp terminals. *Figures 12.3-7 and 12.3-8* show the 1,320 feet access control area as measured from the Interstate-82 ramp terminal intersections. As shown, 6 private and 4 public accesses are located within the 1,320-foot control area on either side of the interchange. The presence of the signalized Brownell Boulevard intersection located less than 200 feet west of the southbound ramp terminal, along with the existing private driveways and Port of Entry entrance, will be important access planning elements to be explored as part of future alternatives analyses.

Table 12.3-4 EXISTING PUBLIC/PRIVATE ACCESS APPROACH INVENTORY

Figure ID	Roadway	Approach Type	Side of Roadway	Serves Tax Lot Number	Property Owner/ Business Name	Mile Point	Approach Width	Permitted?/ Permit #	Date of Permit
1	US 730	Public	North	-	DeVore Road	184.87	83'	19417	1/14/1972
2	US 730	Private	North	5N 28 16AA, 1100, 1101, 1102, 1103	Residential	184.779	16'	Not Permitted	-
3	US 730	Private	North	5N 28 16AA, 102	Residential	184.695	25'	Not Permitted	-
4	US 730	Public	North	-	Scaplehorn Road	184.32	67'	Not Permitted	-
5	US 730	Private	North	5N 28 16 , 700, 800, 900, 1000, 1100	Commercial (Umatilla Self Storage)	184.248	38'	22356	4/16/1976
6	US 730	Public	North	-	I-82 NB Ramp Terminal (On-ramp)	184.17		-	-
7	US 730	Public	North	-	I-82 SB Ramp Terminal (Off-ramp)	184.08		-	-
8	US 730	Public	North	-	Brownell Boulevard	184.03	111'	Not Permitted	-
9	US 730	Public	North	5N 28 16BC, 100	Port of Entry Entrance	184.01	130'	Not Permitted	-
10	US 730	Public	South	-	Umatilla River Road	183.66	105'	Not Permitted	-
11	US 730	Public	South	-	Eisele Drive	183.88	50'	Not Permitted	-
12	US 730	Private	South	5N 28 16BC, 500	Commercial (US Post Office Employee Entrance)	183.92	18'	12A35034	10/01/1993
13	US 730	Private	South	5N 28 16, 1300, 1400	Commercial (Crossroads Truck Stop)	183.94	40'	29165	5/10/1986
14	US 730	Private	South	5N 28 16, 1300, 1400	Commercial (Crossroads Truck Stop)	183.991	67'	29165	5/10/1986
15	US 730	Private	South	5N 28 16, 1500	Commercial (Crossroads Truck Stop)	184.03	65'	Not Permitted	-
16	US 730	Public	South	-	I-82 SB Ramp Terminal (On-ramp)	184.08	-	-	-
17	US 730	Public	South	-	I-82 NB Ramp Terminal (Off-ramp)	184.17	-	-	-
18	US 730	Private	South	5N 28 16, 1700	Commercial (Road to Rock Pit)	184.29	44'	Not Permitted	-
19	US 730	Private	South	5N 28 16AD, 400	ODOT Stockpile site	184.692	23'	Not Permitted	-
20	US 730	Private	South	5N 28 16AD, 200	Commercial (closed fruit stand)	184.696	20'	Not Permitted	-
21	US 730	Private	South	5N 28 16AD, 200	Commercial (closed fruit stand)	184.731	48'	Not Permitted	-
22	US 730	Private	South	5N 28 16AD, 100	Residence	184.771	29'	Not Permitted	-
23	US 730	Public	South	-	Lind Road	184.78	29'	Not Permitted	-
24	US 730	Public	South	-	Connection to US 395	184.81	-	Not Permitted	-
25	US 730	Public	South	-	US 395	184.87	-	Not Permitted	-

H:\profile\10369 - I-82 US 730 IAMP\GIS\UmatillaAccessInventoryA.mxd

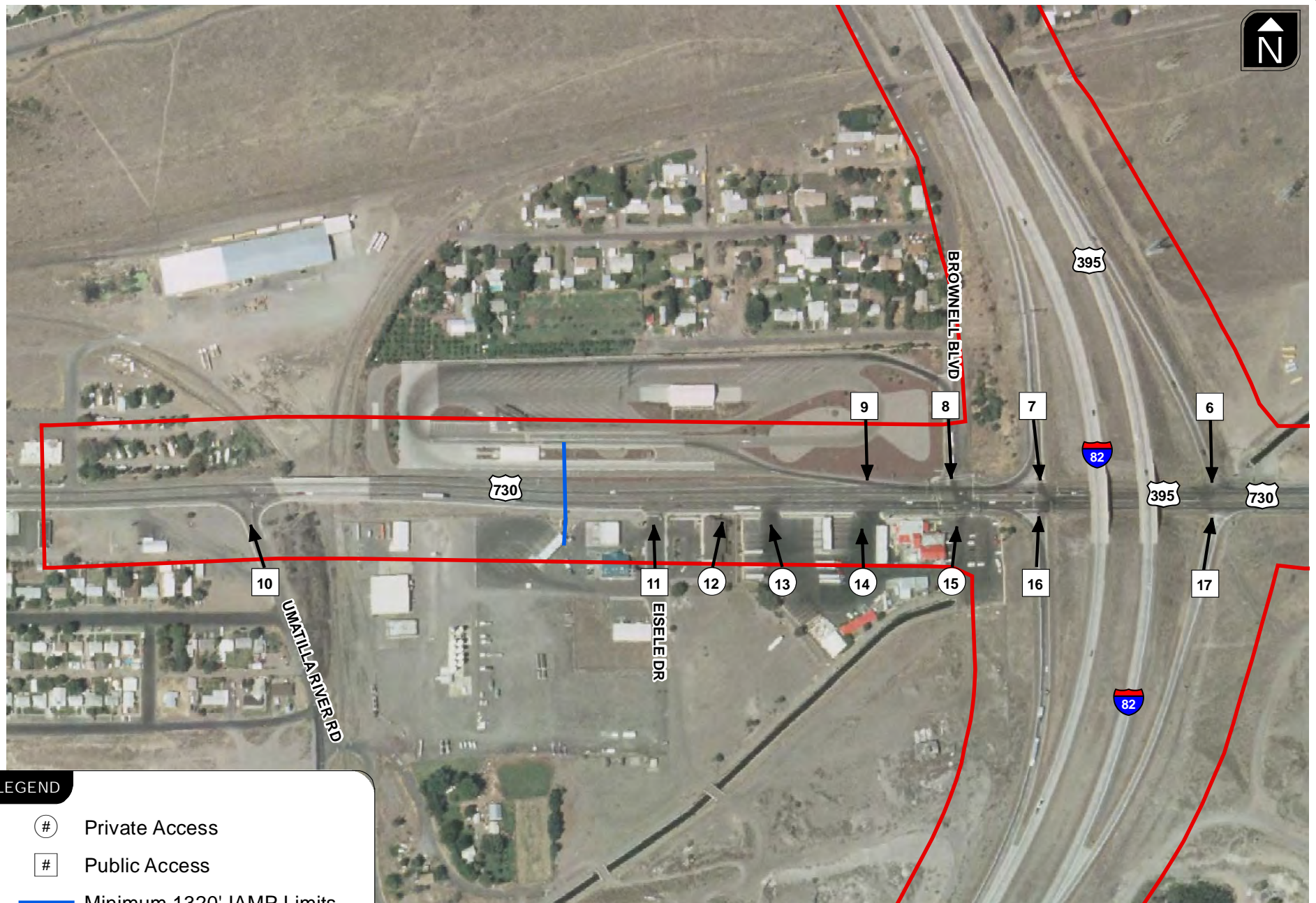

LEGEND

- # Private Access
- # Public Access
- Minimum 1320' IAMP Limits
- ▭ Operations/Access Study Area

ACCESS INVENTORY
WEST OF I-82 AND I-82 RAMPS
UMATILLA, OREGON **FIGURE**

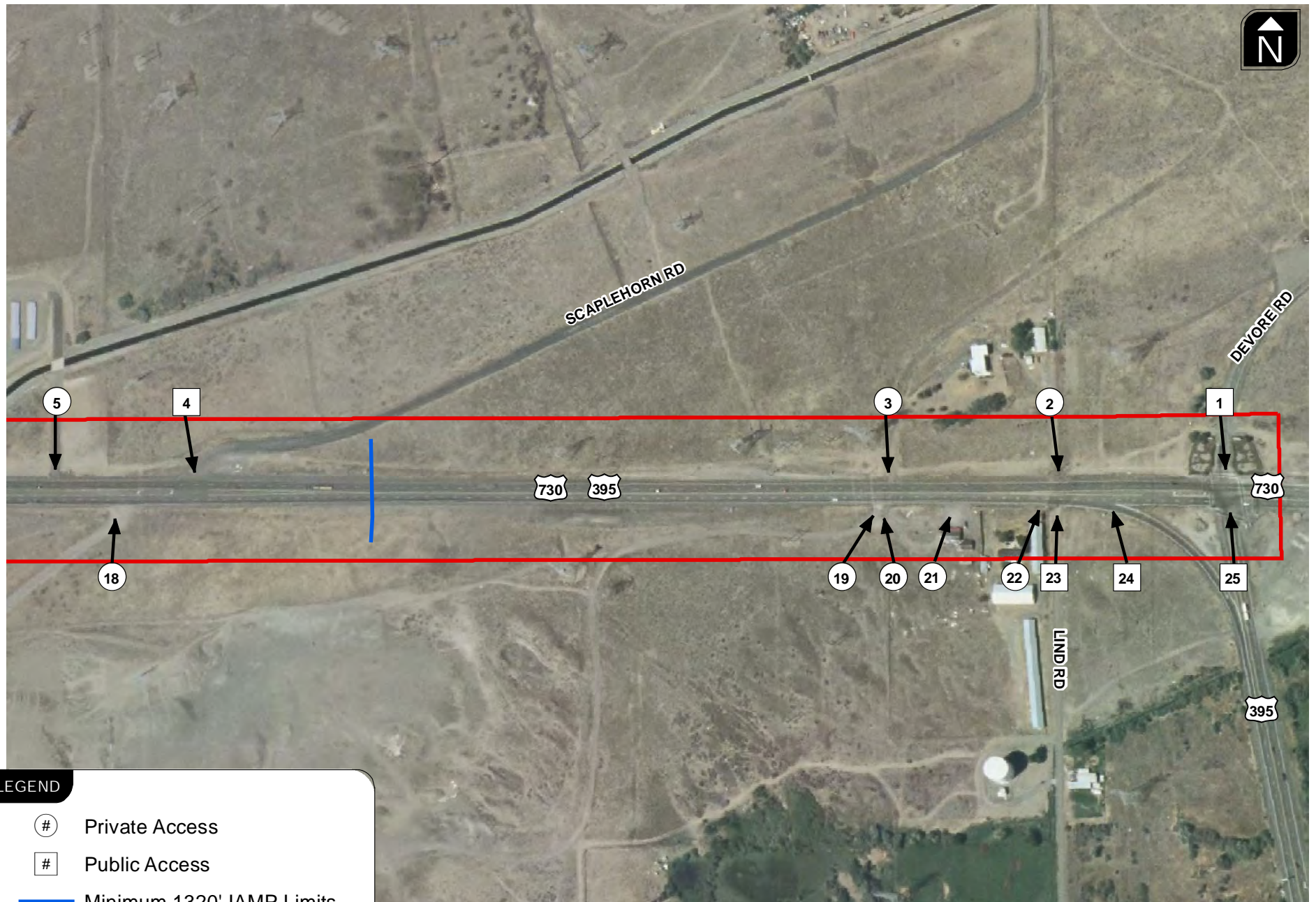

H:\p\office\10369 - I-82 US 730 IAMP\GIS\UmatillaAccessInventoryB.mxd

LEGEND

- # Private Access
- # Public Access
- Minimum 1320' IAMP Limits
- ▭ Operations/Access Study Area

ACCESS INVENTORY EAST OF I-82 UMATILLA, OREGON **FIGURE**

12.3.460 Existing Roadway Deficiencies

No significant existing roadway deficiencies were identified within the IMSA along the paved sections of roadway.

12.3.470 Environment

The existing environmental conditions and potential issues were identified. The following is a summary of potential environmental issues, permits, and additional actions that may be required as the project moves forward. A more detailed description of these items and the baseline conditions may be found in the Technical Appendix.

12.3.470(1) Clean Water Act Section 404/Wetlands/Waters of US

A Section 404 Permit and a Removal/Fill Permit may be needed if the project crosses the Brownell Ditch or impacts the wetlands on the north end of the IAMP study area. Clear-spanning the Brownell Ditch would be the preferred option to avoid impacts and eliminate the need for the permits.

12.3.470(2) Cultural Resources

The SHPO records search revealed nearly 30 cultural resources sites within a 1-mile radius of the IAMP study area. Locations of known cultural resources sites, along with coordination with the Confederated Tribes of the Umatilla Indian Reservation (CTUIR) should be included as part of the alternative design process to avoid known sites to the extent possible.

12.3.470(3) Section 4(f)

Given the amount of cultural resources and the Lewis and Clark Commemorative Trail within and adjacent to the IAMP study area, a Section 4(f) analysis will be required as part of the environmental review for the project if these facilities are impacted. These resources should be considered during the alternative design to avoid impacting them to the extent possible.

12.3.470(4) HAZMAT

There is a HAZMAT site in the southeast quadrant of the US 730/US 395-Devore Road intersection. This property and the potential issues associated with impacting it should be taken into consideration when designing any projects for this intersection.

12.3.480 Summary

The primary roadways within the Interchange Management Study Area (IMSA) include Interstate-82, US 730 and US 395.

All of the study intersections meet their respective ODOT mobility standard; however, the primary issue in the area is truck traffic circulation to and from the Umatilla Port of Entry. For inbound truck traffic, the problem is the close spacing of the Brownell Boulevard and I-82 Southbound terminal signalized intersections and the Umatilla Port of Entry entrance. Queues back up from the Port of Entry onto US 730 and the I-82 SB off-ramp, which forces the Port of

Entry to close its weigh scales to allow the queue to clear. Outbound truck traffic queues up on Brownell Boulevard back to the Port of Entry exit during peak times, as well.

There are no identified safety issues within the study area based on a review of the most recent five years of available crash data. However, it has been noted that there is a sight line issue for vehicles traveling westbound on US 730 and the ability to see in advance the traffic signal heads at the SB ramp terminal.

Pedestrian and bicycle facilities are limited in the study area.

There are currently 21 access points located within the Operations and Access Study Area (roughly ½-mile to the north and south of the interchange) along US 730. The existing access points are a combination of public and private approaches.

ODOT's access spacing standard within the vicinity of the interchange is 1,320 feet (¼-mile) from the ramp terminals to any type of access (partial or full). Within this ¼-mile control area there are 6 private access points and 4 public accesses.

Potential impacts to cultural resources and the Brownell Ditch will need to be identified as the project moves forward.

12.3.500 2030 FUTURE CONDITIONS

This section documents the future land use as well as the forecast traffic operations in the vicinity of the I-82/US 730 interchange. The future traffic projections are based on anticipated future land uses. Future land use information was determined through working with the City. Two future land use scenarios were developed for the purposes of projecting traffic conditions, in addition to the assumed regional growth outside of the Interchange Management Study Area (IMSA). The first land use scenario (Land Use Scenario #1) focuses on a reasonable full build-out of all vacant or re-developable land within the study area using the current City of Umatilla and Umatilla County zoning. Recognizing the potential for future City annexation and land use intensification in various parts of the study area, a second future sensitivity land use scenario (Land Use Scenario #2) was developed for informational purposes and to help the City establish future annexation thresholds. Land Use Scenario #1 is described and analyzed in this section. Information on and analysis of Land Use Scenario #2 can be found in the Technical Appendix.

12.3.510 Future Land Uses

The analysis of future land uses within the vicinity of the I-82 / US 730 interchange was focused on parcels that are expected to have development or redevelopment potential that would generate traffic within the I-82/US 730 interchange study area. The IMSA defined in *Figure 12.3-2* includes land both inside and outside the city limits and contains a variety of land uses, including commercial, residential, light industrial, general rural, and exclusive farm use.

12.3.511 Sub-Area Analysis

For the purposes of forecasting future development potential and access alternatives, the study area has been divided into six sub-areas, as illustrated in *Figure 12.3-9*. The sub-areas were

defined based on current zoning (shown in *Figure 12.3-10*), the travel-shed served, and point of primary access to the regional transportation network.

12.3.511(1) Sub-Area “A”

Sub-area “A” is located in the northwest corner of the IMSA and is bordered by I-82 to the east, US 730 to the south, the Columbia River to the north, and Switzler Avenue to the west. The majority of land within Sub-Area “A” is within the City of Umatilla city limits and is zoned R-2 (Multi-Family Residential), M-1 (Light Industrial), or GC (General Commercial). A small section of land that is Umatilla County zoned R-3 (Multi-Family Residential) resides just north of the GC zone. Vacant/redevelopable land in Sub-Area “A” is limited to the R-2 and M-1 zones.

12.3.511(2) Sub-Area “B”

Sub-Area “B” is located in the southwest corner of the IMSA and is bordered by I-82 to the east, US 730 to the north, and Umatilla River Road to the south and west. With the exception of City zoned GC and M-1 land along the US 730 and Umatilla River Road corridors, the majority of the remaining land in Sub-Area “B” is Umatilla County zoned F-2 (General Rural).

12.3.511(3) Sub-Area “C”

Sub-Area “C” is located in the northeast corner of the IMSA and is bordered by US 730 to the south, I-82 to the west, the Columbia River to the north, and the McNary residential area to the east. The vast majority of Sub-Area “C” is comprised of Umatilla County zoned F-1 (Exclusive Farm Use) land. Some smaller pockets of City zoned R-1 (Single-Family Residential), R-2, and GC land exists along the US 730 corridor and along Scaplehorn Road.

12.3.511(4) Sub-Area “D”

Sub-Area “D” is located in the southeast corner of the IMSA and is bordered by US 730 to the north, I-82 to the west, US 395 to the east, and Union Street to the south. Almost all of the land within Sub-Area “D” is outside the Umatilla City limits and is zoned primarily under the Umatilla County F-1, M-1, M-2, and C-1 (Commercial) zones.

12.3.511(5) Sub-Area “E”

Sub-Area “E” is located in the southeast quadrant of the US 730/US 395 intersection. Known locally as Buck’s Corner, all of the land within this Sub-Area is located in the Umatilla City limits and is zoned GC.

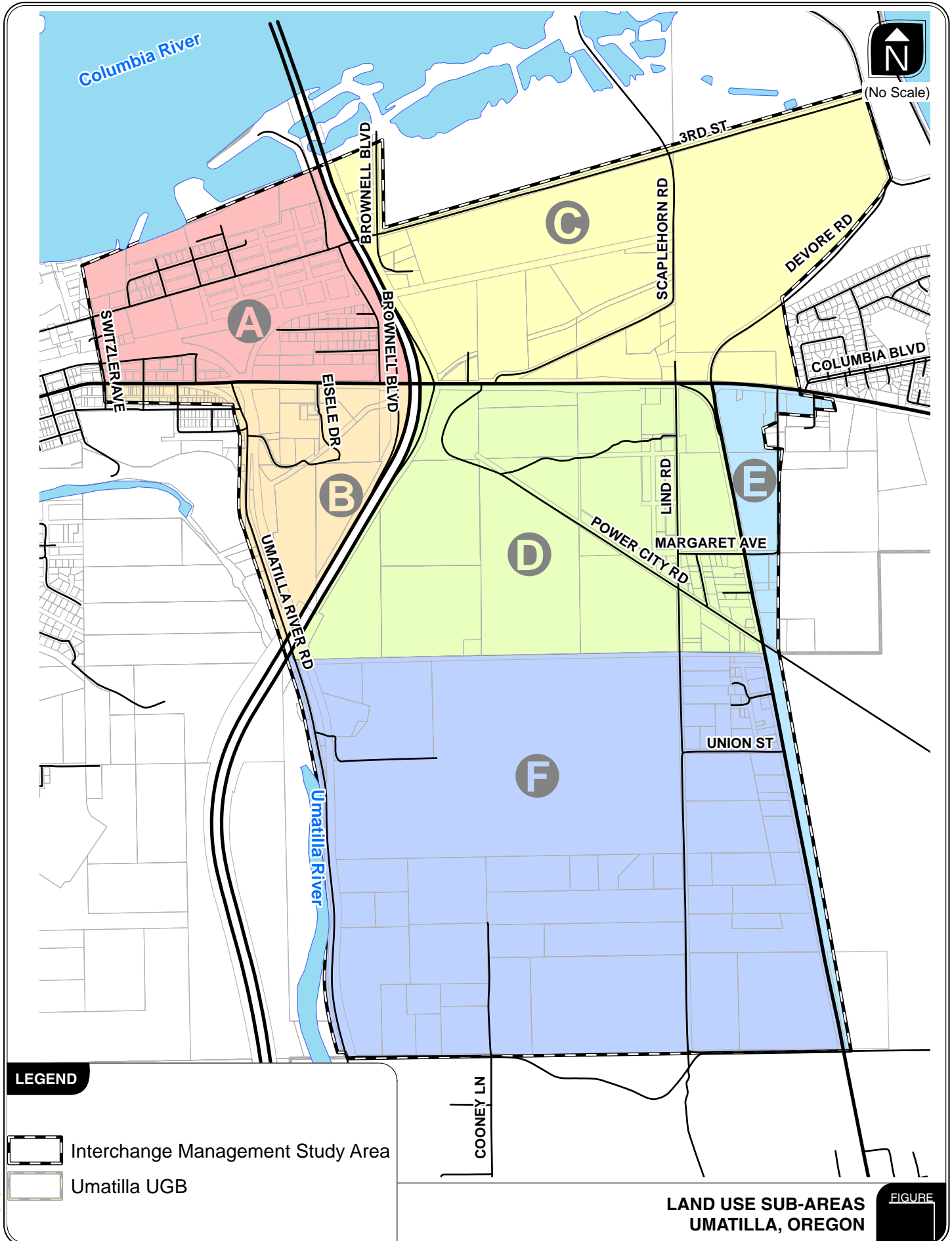

12.3.511(6) Sub-Area “F”

Sub-Area “F” is located directly south of Sub-Area “D” and is bordered on the west by Umatilla River Road, on the south by Bensel Road, and on the east by US 395. Much of this land is Umatilla County zoned F-1 and F-2 and is not likely to develop or redevelop within the timeframe of this study. Therefore no additional development or redevelopment was examined in this sub-area.



H:\profiles\110369 - I-82 US 730 IAMP\GIS\FutureConditionsL andUseSubAreas.mxd

LEGEND

-  Interchange Management Study Area
-  Umatilla UGB

**LAND USE SUB-AREAS
UMATILLA, OREGON**

FIGURE

Figure 12.3-9

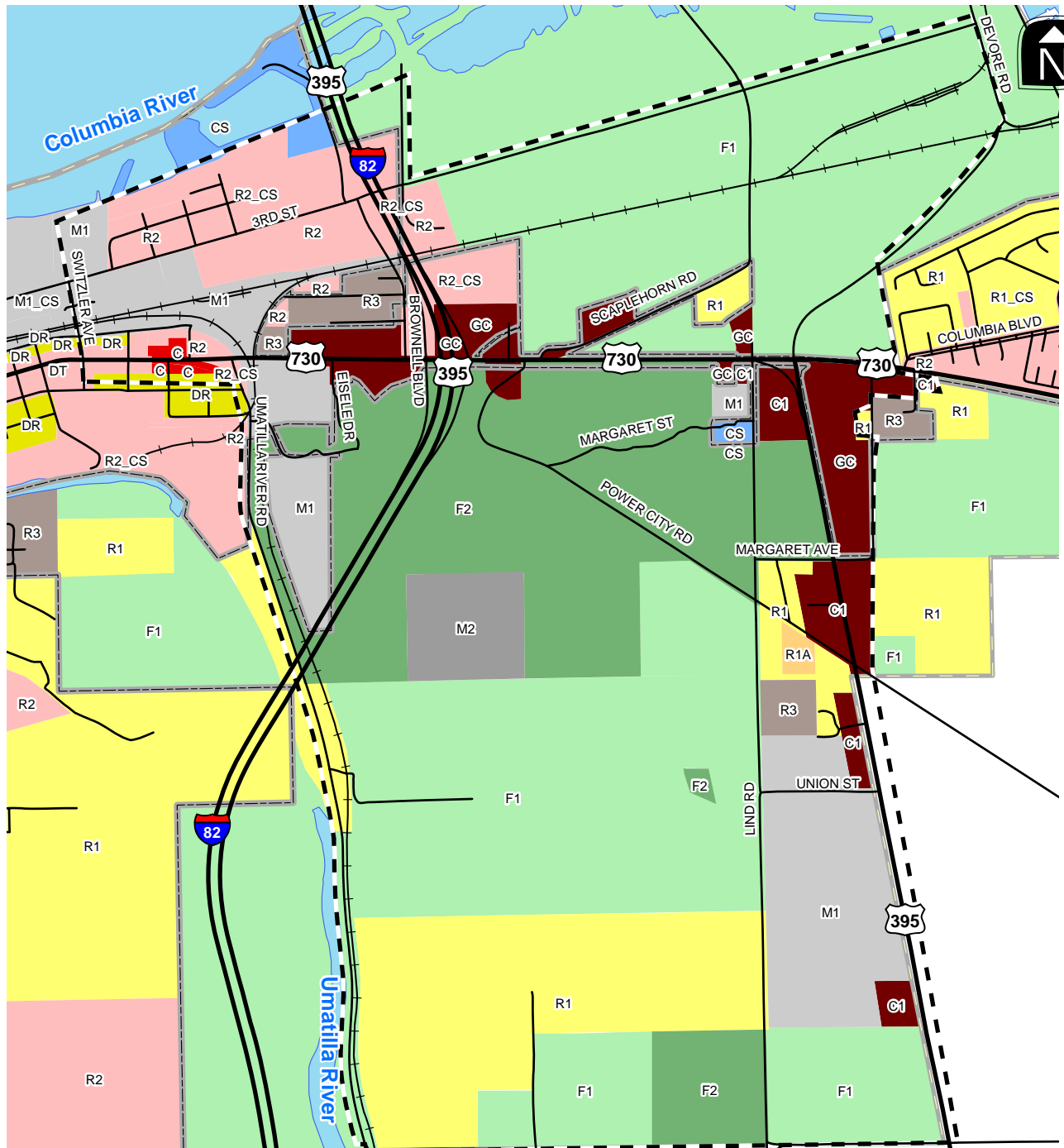

LEGEND

- Land Use Study Area
- Umatilla UGB
- Umatilla City Limits
- Zone**
- Commercial (C)
- Community Service (CS)
- Downtown Residential (DR)
- Downtown Transitional (DT)
- Exclusive Farm Use (F1)
- General Commercial (C1, GC)
- General Rural (F2)
- Heavy Industrial (M2)
- Light Industrial (M1)
- Residential, Multi-Family - Apartments (R3)
- Residential, Multi-Family (R2)
- Single Family Residential (R1)
- Two Acre Residential (R1A)

**STUDY AREA ZONING
UMATILLA, OREGON**

FIGURE

H:\profile\110369 - I-82 US 730 IAMP\GIS\FutureZoningMap.mxd

12.3.520 Future Traffic Conditions

Based on the potential levels of development and redevelopment in the land use sub-areas described above, and factoring in regional growth from outside the IMSA, future year 2030 traffic conditions were estimated along the study area roadways.

12.3.521 Year 2030 No-Build Traffic Volumes Forecast Methodology

Year 2030 “No-Build” traffic volume forecasts for intersection turning movements and street segments were developed in order to analyze the effects of traffic growth on the I-82 / US 730 interchange and the surrounding transportation system. The year 2030 No-Build scenario was developed based on the currently adopted City of Umatilla and Umatilla County comprehensive plans. The remainder of this section describes the methodology and assumptions used to develop year 2030 forecasts.

Future year 2030 no-build traffic volumes were developed by considering the following traffic growth through year 2030:

- Future traffic growth related to development and redevelopment of land in the vicinity of the I-82/US 730 Interchange (including sub-areas ”A” through “E”).
- Future traffic related to regional growth within the larger context of the City of Umatilla, Umatilla County, and along the US 730, US 395, and I-82 corridors.

The specific assumptions used in each of these traffic growth components are summarized below.

12.3.521(1) Development and Redevelopment Traffic

Based on a detailed review of the study area and conversations with City staff, Table 12.3-5 identifies the estimated re-developable acreage in each sub-area, its corresponding zoning, and the primary points of access to the regional transportation network.

As shown in Table 12.3-5, portions of sub-areas ‘A’, ‘C’, and ‘E’ have the greatest potential for development and each gain access to the I-82/US 730 interchange via direct or indirect connections to US 730. To account for local traffic growth attributed to the development in these sub-areas, the project team assumed future land uses based on current zoning and calculated the reasonable build-out trip-generating potential of the properties.

The reasonable build-out trip-generation potential of each parcel was estimated using a two-step approach. Step one included reducing the developable or re-developable area (summarized in Table 12.3-5) by 20 percent to account for utility and roadway right-of-way. Step two applied a Floor Area Ratio (FAR) of 0.25 for commercial zones and 0.40 for industrial lands. Table 12.3-6 provides a summary of the development assumed to occur under this process.

Table 12.3-5 Future Conditions Sub-Area Analysis Zones

Sub-area	Zoning Classifications	Estimated Re-Developable Land (Acres)	Non-Buildable (Acres)	Net Total Re-Developable Land (Acres)	Primary Access
A	GC (City)	0 ¹	0	0	
	R-2 (City)	31.00	0	31.00	Brownell Boulevard and 3 rd Street
	M-1 (City)	25.63	12.15 ³	13.48	3 rd Street
	R-3 (County)	0 ²	0	0	
B	GC (City)	0 ²	0	0	
	M-1 (City)	0 ²	0	0	
	F-2 (County)	57.04	49.42 ⁴	7.62	Eisele Drive
C	GC (City)	15.10	9.00 ²	6.10	US 730 and Scaplehorn Road
	R-2 (City)	13.09	10.90 ⁵	2.19	3 rd Street
	R-1 (City)	6.40	0	6.40	Scaplehorn Road
	F-1 (County)	453.20	453.20 ²	0	
D	F-1 (County)	34.30	0	34.30	Power City Road & Lind Road
	F-2 (County)	175.50	175.50 ^{2,5}	0	
	M-1 (County)	4.80	4.80 ²	0	
	M-2 (County)	35.70	35.70 ⁶	0	Power City Road & Margaret St
	C-1 (County)	7.80	0	7.80	Lind Road
E	GC (City)	27.00	10.00 ³	17.00	US 730 and US 395
Total		886.56	760.67	125.89	

¹ This land is currently occupied by the Port of Entry.
² Land is currently built out or owned/occupied by an existing use that is likely to remain in the long-term.
³ Portion of the land is likely constrained by geographic, environmental, or cultural resources.
⁴ Future intensification of development likely inhibited due to lack of access across irrigation canal.
⁵ Future development likely limited by presence of utility towers and power line easements.
⁶ Future intensification of development likely inhibited due to lack of water infrastructure.

Based on the information contained in Table 12.3-6, the trip generation potential for each of the land uses was calculated for the weekday p.m. peak hour using the 8th Edition of *Trip Generation*, published by the Institute of Transportation Engineers (ITE, Reference 5). The total trip generation potential of the land use scenario shown above was estimated to be 832 total net new trip ends (371 incoming and 461 outgoing) during the weekday p.m. peak hour. The Technical Appendix contains the estimates of net new trips generated by each sub-area. The assumed distribution patterns of trips generated within each sub-area were based on the existing zoning, existing travel patterns, and relative attractions within the overall study area.

12.3.521(2) Background Traffic Growth

Proposed annual growth rates were determined for the various roadways within the study area. The proposed annual growth rates were determined based on a review of ODOT’s Future Year Volume Tables, historical ADT counts, and future development assumptions within the study area. The growth was applied to the existing traffic volumes shown in the *Existing Transportation/Land Use Conditions* section to obtain future year forecast volumes.

Table 12.3-6 I-82 / US 730 Development Assumptions

Land Use	Total Re-Developable Land (Acres)	Industrial or Commercial				Residential	
		Utilities and ROW (20%)	Net Re-developable Land Area (Acres)	FAR	Size (1,000 Sq. Feet GLA)	Allowable Density	Units
<i>Sub-Area "A"</i>							
R-2 Multi-Family	31.00					1	31-acre Athletic Field Complex ¹
M-1 Light Industrial	13.48	(2.70)	10.78	0.40	188		
<i>Sub-Area "B"</i>							
F-2 (County General Rural)	7.62					0.05 unit/acre	10,000 of Industrial Storage Yard ²
<i>Sub-Area "C"</i>							
GC General Commercial	6.10	(1.22)	4.88	0.25	53		
R-2 Multi-Family Residential	2.19					12.4 units/acre	27 Apartments
R-1 Single Family Residential	6.40					5.4 units/acre	34 homes
<i>Sub-Area "D"</i>							
F-1 Exclusive Farm use	34.30					0.05 units/acre	2 homes
C-1 General Commercial	7.80	(1.56)	6.24	0.25	68		
<i>Sub-Area "E"</i>							
GC General Commercial	17.00	(3.40)	13.60	0.25	148		
Total	125.89	(8.88)	35.50		457		

¹ Although zoned for multi-family residential, discussions with City staff concluded that this site is likely better suited for recreational athletic fields which is an allowed conditional use under the R-2 zoning.

² Given the location of the F-2 zoned land near the US 730 corridor, it was assumed that the site is less desirable for residential uses and more appropriate for a higher intensive use such as an industrial storage yard.

12.3.521(3) US 730 & US 395

An annual Local Growth rate was applied to the existing through volumes along US 730, all turning movements at the I-82 ramp terminals, and turning movements to/from US 395. Based on a review of ODOT’s Future Volume Tables (which are based on historic traffic volumes), a Local Growth rate was estimated for the I-82/US 730 IMSA based on three data point locations along the US 730 corridor as shown in Table 12.3-7. Upon reviewing the data points, the project team and ODOT staff concluded that an annual growth rate of 1.3% was the most reasonable and conservative estimate for the study corridor given the degree of variation in the other two data points. Therefore, through traffic volumes on US 730 from 2009 were increased by 27% to the forecast year 2030.

Table 12.3-7 Background Growth Rate Calculations on US 730

Mile Point	Location	Average Annual Daily Traffic		R-Squared Value	Per Year Growth Rate (2008-2028) ¹
		2008	2028		
183.63	0.50 mile west of I-82	8,300	9,600	0.58	0.8%
184.63	0.50 mile east of I-82	10,100	12,800	0.76	1.3%
184.97	0.10 mile east of US 395	7,700	10,100	0.89	1.6%

¹ Per Year Growth Rate = [(2028 AADT– 2008 AADT) / (2008 AADT)] / (2028 – 2008)

12.3.521(4) I-82

The I-82 Traffic Growth rate was applied to the existing through traffic volumes to forecast future traffic projections for I-82. A review of Traffic Volume Tables on I-82 north and south of the I-82 / US 730 interchange indicates that the interstate traffic volume have been increasing over the past 10 years. Based on a review of ODOT’s Future Volume Tables (which are based on historic traffic volumes), a background growth rate was estimated for I-82 near the US 730 interchange. Two data points on I-82 were used in the calculation, one on each side of the interchange. To determine a growth rate estimate, volumes for the year 2008 were compared with ODOT’s 2028 estimates. Table 12.3-8 illustrates the estimated growth rates.

Table 12.3-8 Background Growth Rate Calculations on I-82

Mile Point	Location	Average Annual Daily Traffic		R-Squared Value	Per Year Growth Rate (2008-2028) ¹
		2008	2028		
0.58	Umatilla Bridge ATR 0.58 mile south of Oregon-Washington State line	16,400	18,700	0.96	0.7%
1.30	0.30 mile south of US 730	10,400	12,400	0.90	1.0%
Average					0.85%

¹ Per Year Growth Rate = [(2028 AADT– 2008 AADT) / (2008 AADT)] / (2028 – 2008)

The R-Squared Value indicates the degree of correlation between the dependent variable (historical traffic volume) and the independent variable (time). ODOT’s Analysis Procedures Manual (Reference 3) states that values over 0.75 are preferred, which indicates that the chosen locations are acceptable for this analysis. As shown in Table 12.3-8, a 0.85% annual growth rate was identified for background traffic volumes on I-82 in the vicinity of the US 730 Interchange. Therefore, through traffic volumes on I-82 from 2009 will be increased by 18% to the forecast year 2030.

12.3.522 Planned Transportation Improvements

In general, there are no transportation improvements inside the IMSA that are identified in ODOT’s Statewide Transportation Improvement Plan (STIP) or Umatilla County’s Transportation System Plan. However, the City of Umatilla’s Transportation System Plan has identified the need for signalization of the US 730/Umatilla River Road intersection when

warranted by traffic volumes. There are currently no plans to install a traffic signal at this location in the near future.

12.3.523 Year 2030 No-Build Traffic Conditions

Future year 2030 No-Build weekday p.m. peak hour traffic volumes were determined for each future scenario by applying growth rates and trip generation estimates to the existing traffic network. The resulting year 2030 No-Build weekday p.m. peak hour traffic volumes for are shown in *Figure 12.3-11*.

All operational analyses were performed in accordance with the procedures stated in the 2000 *Highway Capacity Manual* (Reference 4). The OHP (Reference 1) sets operational standards based on volume-to-capacity (v/c) ratios for the interchange ramp terminals (v/c of 0.80 for the northbound ramp terminal and 0.85 for the southbound ramp terminal), intersections of US 730 (v/c of 0.85 between Brownell Boulevard and Sloan Avenue and v/c of 0.70 east of I-82), and US 395 (v/c of 0.70). These standards apply to the overall v/c ratio at signalized intersections and to the state highway approaches at unsignalized intersections. The minor street approaches that are stop-controlled at unsignalized intersections have a standard of a v/c ratio of 0.90.

Traffic operations analyses were performed for the study intersections using the forecast year 2030 “No-Build” weekday p.m. peak hour traffic volumes as shown in *Figure 12.3-11*. Table 12.3-9 below summarizes the deficiencies projected. The Technical Appendix contains the detailed analysis worksheets.

As Table 12.3-9 shows, the US 730/US 395-Devore Road intersection is forecast to operate over the applicable OHP mobility standard. The left-turn from the I-82 Northbound ramp terminal onto US 730 is forecast to operate with lengthy delays (LOS “F”). However, the OHP mobility standard is based on v/c ratio and this movement is forecast to have an acceptable v/c ratio.

Table 12.3-9 Forecast Deficiencies

Intersection	Fails to Meet Applicable OHP Standard¹	Meets Standard, but Lengthy Delays²
US 730/Umatilla River Rd		X
US 730/Brownell Blvd		X
US 730/I-82 SB Ramps		X
US 730/I-82 NB Ramps		X
US 730/Lind Rd		X
US 730/US 395-Devore Rd	X	

¹ Source: 1999 Oregon Highway Plan including Amendments November 1999 through January 2006 - Table 6 (Maximum Volume to Capacity Ratios Outside Metro) as amended August 2005, OHP Amendment 05-16

² Level-of-Service “D” or worse for signalized intersection and LOS “E” or worse for unsignalized intersection.

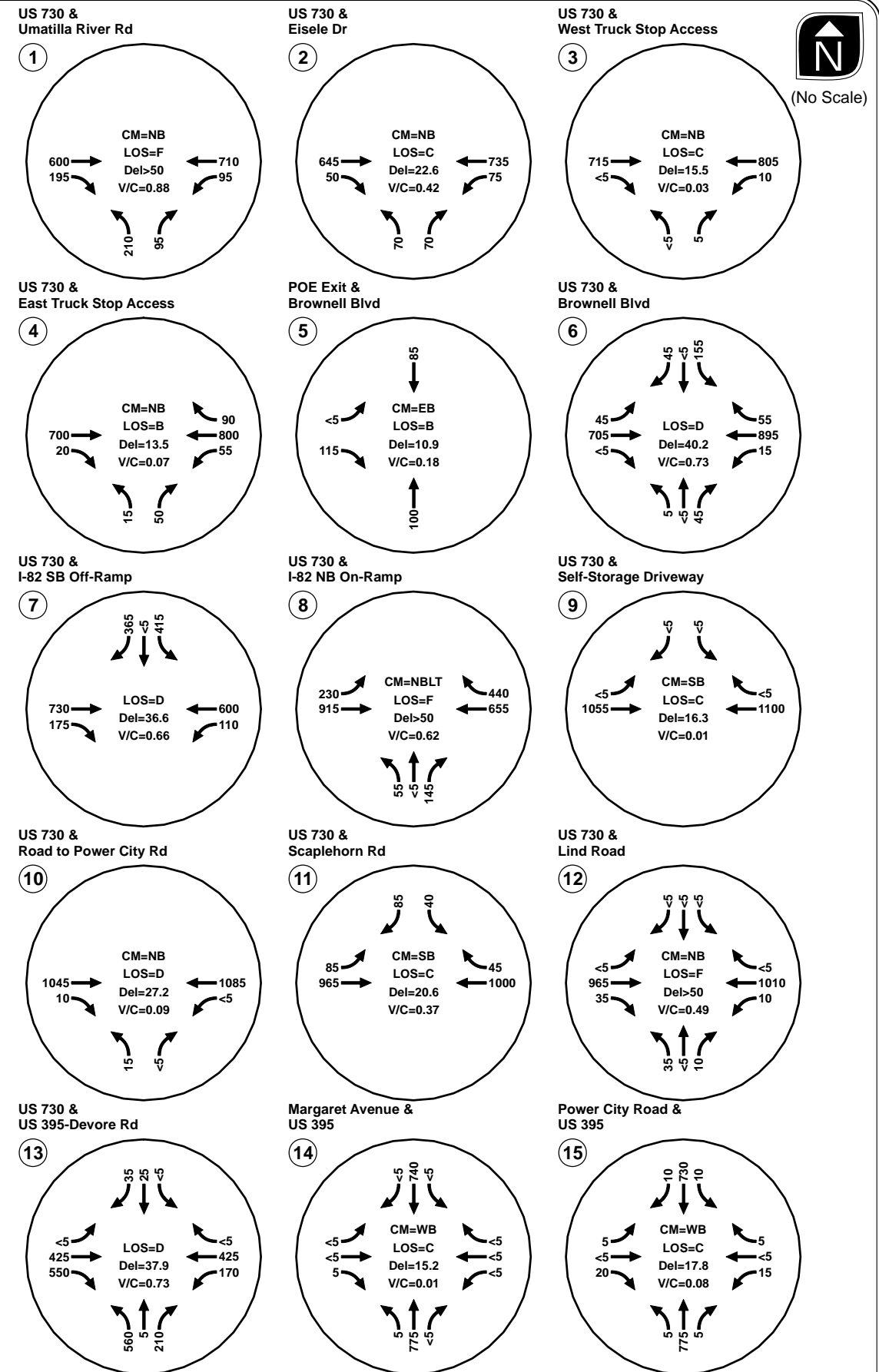
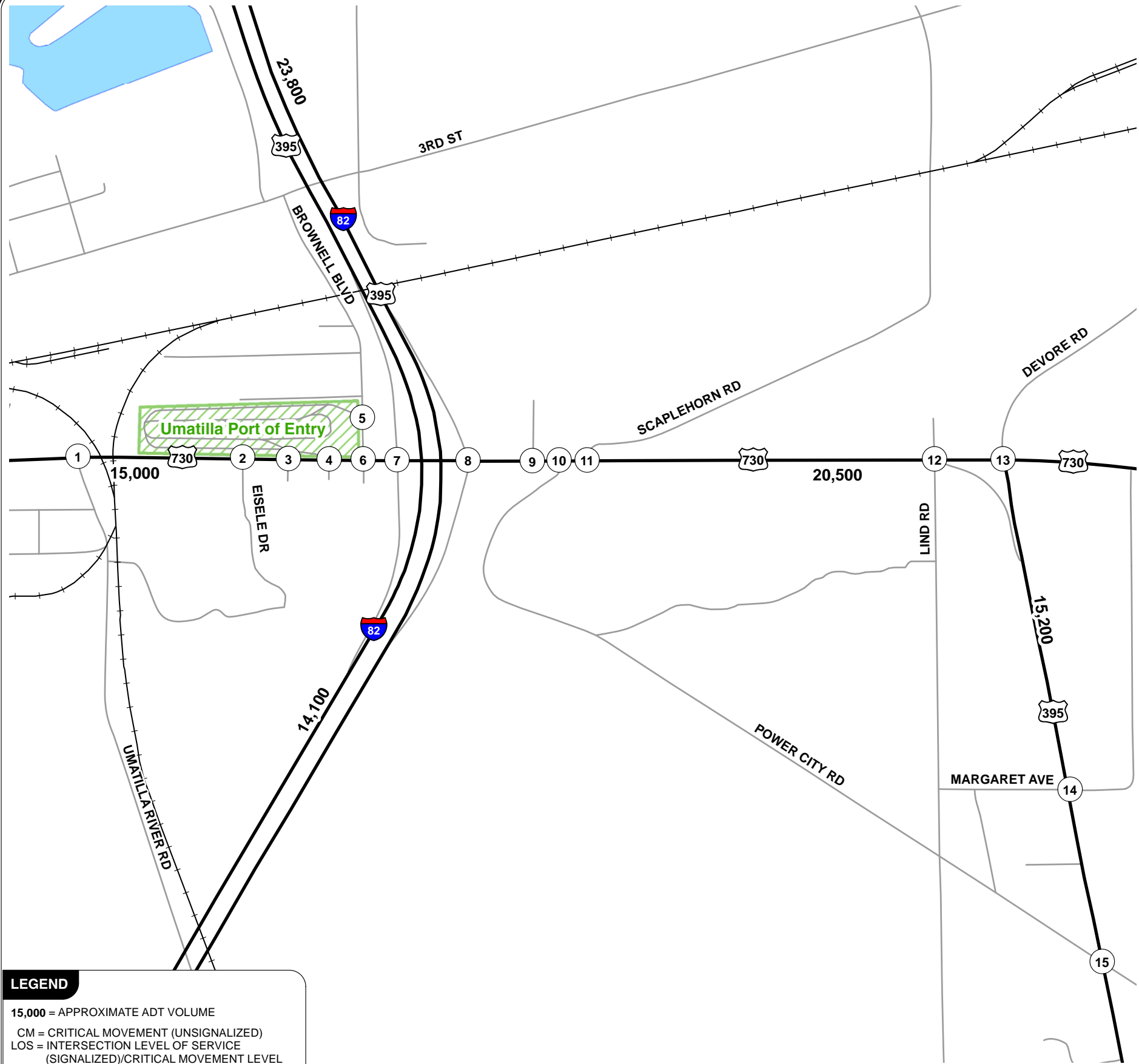

LEGEND

15,000 = APPROXIMATE ADT VOLUME

CM = CRITICAL MOVEMENT (UNSIGNALIZED)

LOS = INTERSECTION LEVEL OF SERVICE (SIGNALIZED)/CRITICAL MOVEMENT LEVEL OF SERVICE (UNSIGNALIZED)

Del = INTERSECTION AVERAGE CONTROL DELAY (SIGNALIZED)/CRITICAL MOVEMENT CONTROL DELAY (UNSIGNALIZED)

V/C = CRITICAL VOLUME-TO-CAPACITY RATIO

YEAR 2030 TRAFFIC CONDITIONS 30TH HIGHEST HOUR UMATILLA, OREGON FIGURE

H:\p\profile\10369 - I-82 US 730 IAMP\GIS\FutureConditionsOps.mxd

It is important to note that these results examine the intersections in isolation. Issues related to queue spillback and signal coordination between the closely spaced signalized I-82 Southbound ramp terminals and Brownell Boulevard intersections were discussed in the *Existing Transportation/Land Use Conditions* section. These problems that exist will be exacerbated by the increasing traffic volumes at these intersections if no improvements are made.

12.3.600 IAMP CIRCULATION AND ACCESS CONCEPT DEVELOPMENT AND ANALYSIS

This section documents the development and evaluation of the local circulation and access concepts for the IAMP. Twelve unique concepts, plus five variations on certain concepts, were developed and taken through a thorough screening process that included input from Technical Advisory Committee (TAC), Public Advisory Committee (PAC), local property and business owners, and the public at-large. Based on results of the initial screening, a refined analysis was conducted that resulted in the identification of the preferred transportation improvement plan. The following subsections document the concepts that were evaluated and the results of the screening process.

12.3.610 Concept Development Process

The development of the initial concepts for the I-82/US 730 Interchange began with three separate design workshops. The first two workshops were held for members of the TAC and PAC committees, while the third workshop was held for interested citizens, business owners, and landowners in a public open house setting. All three workshops were held on April 21, 2010.

Within each workshop, participants were presented with an overview of the existing and future traffic demand within the Interchange Management Study Area (IMSA), the identified operational and safety deficiencies, and the applicable interchange design forms and basic design parameters. Following these presentation overviews, participants were asked to sketch their ideas for improving circulation at the interchange and within the IMSA.

After the completion of the TAC, PAC, and public workshops, the project team took all of the individual design ideas and grouped them into various interchange forms. Each group was further sorted into common and unique interchange form and local circulation concepts. Based on this process, the project team made some technical refinements to the interchange form and local circulation concepts to ensure basic design parameters and principles were being met.

Following the initial design workshops, additional variations to concepts were developed beyond the original designs. These concepts were based on feedback from members of the TAC and PAC, local property and business owners, the general public, and City Council. The additions included:

- Concept 8b was further refined to create Concepts 8c, 8d, and 8e in order to provide access to the relocated POE in such a manner that would meet Federal guidelines and provide the POE staff with the ability to monitor trucks bypassing the POE;
- Concept 3 was refined to allow for the potential relocation of the POE as a second phase; and

- Concept 13 was developed to provide an option where the POE is relocated further south on the I-82 corridor.

The concepts listed above were developed by members of the TAC and PAC, the general public, and the project team.

12.3.620 IAMP Circulation and Access Concept Summaries

Each of the concepts developed for the I-82/US 730 Interchange and their key design components are described below. Improvements to the east side of the interchange and to the sidewalk network along US 730 are essentially the same between all concepts and are described in greater detail in Section 12.3.700. Detailed double-line drawings of concepts that passed the initial screening and moved forward for more detailed analysis can be found later in this section. Single-line illustrations of the other concepts can be found in the Technical Appendix.

12.3.620(1) Concept #1a:

This concept would involve the following changes/improvements:

- The existing southbound off-ramp would be modified to accommodate trucks entering the POE. This would involve disconnecting the off-ramp from US 730 and keeping it elevated to cross over Brownell Boulevard before touching down in the POE near the existing weigh scales. The internal POE circulation system and weigh scales would need to be modified as a result.
- A new southbound exiting loop ramp and on-ramp would be constructed in the southwest quadrant of the intersection.
- Brownell Boulevard would be disconnected from US 730 and rerouted along the Locus Street corridor, travel under US 730 via a widened underpass (currently utilized by the adjacent rail line), and routed along a new roadway that would connect to Eisele Drive on the south side of US 730.
- A new north-south roadway would be constructed along the east side of I-82 to provide better north-south connectivity between US 730 and 3rd Street.
- A new backage road accessed via Eisele Drive would be constructed to provide access and circulation for properties along the south side of US 730.

12.3.620(2) Concept #1b:

This concept would involve the following changes/improvements:

- The existing southbound off-ramp would be modified to accommodate trucks entering the POE. This would involve disconnecting the off-ramp from US 730 and keeping it elevated to cross over Brownell Boulevard before touching down in the POE near the existing weigh

scales. The internal POE circulation system and weigh scales would need to be modified as a result.

- Trucks leaving the POE would continue to access Brownell Boulevard via the current method.
- A new southbound exiting loop ramp and on-ramp would be constructed in the southwest quadrant of the intersection.
- A new north-south roadway would be constructed along the east side of I-82 to provide better north-south connectivity between US 730 and 3rd Street.
- A new backage road accessed via Eisele Drive would be constructed to provide access and circulation for properties along the south side of US 730.

12.3.620(3) Concept #2

This concept would involve the following changes/improvements:

- A new on-ramp to I-82 southbound would be constructed for trucks exiting the POE. This on-ramp would be elevated coming out of the POE in order to clear the existing southbound off-ramp and connect to I-82.
- The existing southbound on-ramp would be lengthened in order to provide the necessary separation from the new southbound POE on-ramp.
- Brownell would be disconnected from US 730 and gain access via 3rd Street to US 730 both east and west of I-82.
- A new north-south roadway would be constructed along the east side of I-82 to provide better north-south connectivity between US 730 and 3rd Street.
- A new backage road accessed via Eisele Drive would be constructed to provide access and circulation for properties along the south side of US 730.

12.3.620(4) Concept #3

This concept would involve the following changes/improvements:

- The existing southbound off-ramp would be closed.
- A new exiting loop ramp and on-ramp would be constructed in the southwest quadrant of the intersection.
- Brownell Boulevard would be realigned to the east to connect to US 730 in the approximate location of the existing southbound ramp terminal. As part of this, the existing Brownell Boulevard intersection with US 730 would be closed.

- A new exiting roadway would be provided from the POE to the realigned Brownell Boulevard.
- A new backage road accessed via Eisele Drive would be constructed to provide access and circulation for properties along the south side of US 730.

12.3.620(5) Concept #3 with Potential POE Relocation

This is a variation of the original Concept 3 to allow for the potential future relocation of the POE south of the interchange. To accommodate a relocated POE at some point in the future, the original Concept 3 would need to be modified as follows:

- A new southbound exit ramp would need to be constructed further north along I-82 just south of the 3rd Street overpass.
- This exit ramp would parallel I-82 (requiring a separate railroad overpass structure) where it would then split, providing access to the exiting loop ramp (depicted in Concept 3) and access to a separate POE access road.
- To accommodate the exit ramp split, the location of the exiting loop ramp would need to be shifted further to the west where it would likely have more substantial impacts to the Crossroads restaurant parking lot.
- The I-82 southbound on-ramp depicted in Concept 3 would need to be relocated further to the west in order to accommodate the future POE. The relocated ramp would need a separate bridge structure over the Umatilla River.
- The Eisele Drive extension as a back-door out of the relocated POE would need to be grade separated (under or over) from the I-82 southbound on-ramp. Due to the anticipated flat grade, grade separation may be difficult to accomplish.
- The I-82 southbound exit out of the relocated POE would require a widening of the existing Umatilla River bridge.

12.3.620(6) Concept #4

This concept would involve the following changes/improvements:

- A new driveway for exiting POE trucks would be constructed along the western side. This new exiting roadway would travel under US 730 via a widened underpass (currently utilized by the adjacent rail line), and routed along a new roadway that would connect to Eisele Drive south of US 730.
- The existing traffic signal at the Brownell Boulevard/US 730 intersection would be removed and Brownell Boulevard would be restricted to right-in/right-out movements.

- A new backage road accessed via Eisele Drive would be constructed to provide access and circulation for properties along the south side of US 730.

12.3.620(7) Concept #5

This concept would involve the following changes/improvements:

- Brownell Boulevard would be disconnected from US 730 and gain access via 3rd Street to US 730 both east and west of I-82.
- A new on-ramp to I-82 southbound would be constructed for trucks exiting the POE. This on-ramp would begin at the POE and travel under US 730 and parallel the existing southbound on-ramp before merging onto I-82.
- A new north-south roadway would be constructed along the east side of I-82 to provide better north-south connectivity between US 730 and 3rd Street.
- A new backage road accessed via Eisele Drive would be constructed to provide access and circulation for properties along the south side of US 730.

12.3.620(8) Concept #6

This concept would involve the following changes/improvements:

- A single point diamond interchange would be constructed at the existing I/82/US 730 interchange.
- A new backage road accessed via Eisele Drive would be constructed to provide access and circulation for properties along the south side of US 730.

12.3.620(9) Concept #7

This concept would involve the following changes/improvements:

- A new exiting loop ramp and on-ramp would be constructed in the southwest quadrant of the intersection with a connection to US 730 at the existing Eisele Drive intersection.
- Brownell Boulevard would be disconnected from US 730 and gain access via 3rd Street to US 730 both east and west of I-82.
- The existing southbound off-ramp would be modified for POE entry traffic. Rather than exit onto US 730, a new alignment would be constructed that would access the POE at the approximate location of the existing POE exiting driveway. This would be accompanied by an internal modification to the POE.
- A new backage road accessed via Eisele Drive would be constructed to provide access and circulation for properties along the south side of US 730.

12.3.620(10) Concept #8a

This concept would involve the following changes/improvements:

- The POE would be relocated to the southwest quadrant of the interchange south of the irrigation canal.
- A new extension and widening of Eisele Drive would provide access to the relocated POE from US 730.
- The existing Brownell Boulevard intersection with US 730 would be closed.
- A new roadway would be constructed through the old POE site and connect Brownell Boulevard to the US 730/Eisele Drive intersection.
- A new backage road accessed via Eisele Drive would be constructed to provide access and circulation for properties along the south side of US 730.

12.3.620(11) Concept #8b

This concept would involve the following changes/improvements:

- The POE would be relocated to the southwest quadrant of the interchange south of the irrigation canal.
- A new extension and widening of Eisele Drive would provide access to the relocated POE from US 730.
- A new truck entrance to the relocated POE would be constructed off of the existing southbound on-ramp. For trucks exiting the POE, a new southbound on-ramp would be constructed to I-82.
- The existing Brownell Boulevard intersection with US 730 would be closed.
- A new roadway would be constructed through the old POE site and connect to Brownell Boulevard to the US 730/Eisele Drive intersection.
- A new backage road accessed via Eisele Drive would be constructed to provide access and circulation for properties along the south side of US 730.

12.3.620(12) Concept #8c

This concept is essentially the same as Concept 8b, with the difference being that Concept 8c eliminates inbound access to the POE from US 730.

12.3.620(13) Concept #8d

Like Concept 8c, Concept 8d relocates the POE south of US 730, Brownell Boulevard is realigned to intersect US 730 across from Eisele Drive, and Eisele Drive extended south to the relocated POE to accommodate egress movements. However, Concept 8d includes a direct access ramp from I-82 Southbound to the relocated POE. As this connection would need to work within the configuration of the existing interchange, it would likely need a new overpass structure over US 730 and then another overpass structure over the existing I-82 Southbound on-ramp.

12.3.620(14) Concept #8e

Concept 8e builds upon Concept 8d by including a secondary connection to the POE from the existing I-82 southbound on-ramp.

12.3.620(15) Concept #9

This concept would involve the following changes/improvements:

- A new truck only slip lane would be constructed off of the existing southbound off-ramp forming a separate westbound travel lane on US 730. This new westbound travel lane would cross Brownell Boulevard and feed into the POE.
- A new exiting loop ramp on on-ramp would be constructed in the southwest quadrant of the intersection with a new ramp terminal constructed at the existing Brownell Boulevard intersection with US 730.
- A new backage road accessed via Eisele Drive would be constructed to provide access and circulation for properties along the south side of US 730.

12.3.620(16) Concept #10

This concept would involve the following changes/improvements:

- A new southbound off-ramp would be constructed for POE traffic. This off-ramp would be elevated over Brownell Boulevard and the adjacent railroad tracks and touch down along the west side of the adjacent residential neighborhood and POE.
- Internal circulation within the POE would be modified to accommodate the new off-ramp and a new exiting driveway that would be routed along the Cherry Street corridor.
- A new backage road accessed via Eisele Drive would be constructed to provide access and circulation for properties along the south side of US 730.

12.3.620(17) Concept #11

This concept would involve the following changes/improvements:

- A new split diamond interchange would be constructed along I-82 with a new northbound off-ramp and southbound on-ramp being located approximately 1,600 feet south of US 730.
- The new ramp terminal would connect to US 730 via an extension of Eisele Drive.
- Internal circulation within the POE would be modified to accommodate a new entering and exiting driveway to US 730 across from the existing Eisele Drive intersection.
- At the Eisele Drive/US 730 intersection, a roundabout would be constructed to facilitate traffic along Eisele Drive and the POE driveway.
- The Brownell Boulevard intersection would be limited to right-in/right-out movements.
- A new backage road accessed via Eisele Drive would be constructed to provide access and circulation for properties along the south side of US 730.

12.3.620(18) Concept #12

This concept would involve the following changes/improvements:

- A double roundabout would be constructed at the southbound ramp terminal and Brownell Boulevard intersection with US 730.
- A new backage road accessed via Eisele Drive would be constructed to provide access and circulation for properties along the south side of US 730.

12.3.620(19) Concept #13

This concept would involve the following changes/improvements:

- The POE would be relocated to the I-82 corridor and a permanent weigh station on US 730 (location to be determined via a separate study) and a temporary truck scale on US 395 (location to be determined via a separate study) would be constructed.
- A new backage road accessed via Eisele Drive would be constructed to provide access and circulation for properties along the south side of US 730.
- The existing Brownell Boulevard intersection with US 730 would be closed.
- A new roadway would be constructed through the old POE site and connect to Brownell Boulevard to the US 730/Eisele Drive intersection

12.3.630 Concept Screening

In order to arrive at the preferred transportation improvement plan, the concepts went through three levels of screening. The first level was a high-level screening to determine if any of the concepts did not meet the basic purpose of the project. After this, a second level was applied to

the concepts involving a qualitative assessment of each concept based on the project's adopted evaluation criteria. Following this screening, the remaining concepts were examined quantitatively to determine the final preferred concepts.

The following section provides detailed explanation of this screening process and identifies which concept was selected by the TAC and PAC as the preferred transportation improvement plan. The Technical Appendix contains more details about the screening process.

12.3.631 Preliminary Purpose and Problem Statement Screening

The project team first performed a preliminary assessment to determine if any of the concepts were not meeting the basic intent of the project purpose and problem statement. The official Purpose and Problem Statement, as approved by the TAC and PAC is outlined below:

Purpose of the Project:

The IAMP is a strategic transportation plan that is designed to protect the long-term function of the Interstate 82 (I-82) / US 730 interchange by preserving the capacity of the interchange while providing safe and efficient operations between connecting roadways. The IAMP will identify land use management strategies, short-term and long-term transportation improvements, access management goals, and strategies to fund identified improvements.

Problem Statement:

The signalized intersections of Brownell Boulevard/US 730 and the southbound I-82/US 730 terminal are located within close proximity of one another resulting in undesirable operations. The signals have been coordinated in an effort to improve intersection operations. Nevertheless, queuing problems associated with truck traffic accessing the Umatilla Port of Entry weigh station continue to occur at the two intersections. This condition varies by season due to increase of trucks during mid-summer and fall harvests.

The Port of Entry (POE) is located on the northwest corner of Brownell Boulevard/US 730 intersection which coincides with the northwest quadrant of the I-82/US 730 interchange. A truck stop, restaurant, fueling station and other commercial development is located in the southwest quadrant. East of the interchange is primarily vacant land within the City of Umatilla Urban Growth Area. This land is zoned exclusive farm use, tourism commercial or public facilities. The City is interested in the economic development potential of this area and would like to develop a local street network plan that supports the safe and efficient operation of the interchange and the US 730/US 395 intersection located within the interchange influence area.

Based on the project's purpose, it was generally concluded that all of the interchange concepts met the basic intent of the project purpose and problem statement.

12.3.632 Basic Qualitative Concept Screening

After the initial Purpose and Problem Statement screening, a basic qualitative screening of the concepts was conducted. To assist in the evaluation process, the adopted evaluation criteria was reviewed and a screening level evaluation process by which each of the interchange form and local circulation concepts could be evaluated at a high level qualitative perspective was

developed. As a part of this process, it was recognized that at this particular level of evaluation, certain evaluation criteria could not be applied to each concept because the criterion was determined to be too specific, required a higher level of detailed information, or was a non-differentiating factor. In these instances, a screening level evaluation was not applied to the concepts. The following outline lists the five screening level categories and the selected evaluation criteria within each category that were investigated as part of this process.

Category #1 – Transportation

Evaluation Criteria – Addresses the existing operational performance issues created by the close spacing between Brownell Boulevard and the southbound ramp terminal

Evaluation Criteria – Improves non-vehicular east-west travel through the interchange

Category #2 – Land Use

Evaluation Criteria – Level of right-of-way (ROW) impacts

Evaluation Criteria – Supports businesses and future economic development

Category #3 – Cost/Implementation

Evaluation Criteria – Level of construction costs

Evaluation Criteria – Construction feasibility

Category #4 – Environmental/Livability

Evaluation Criteria – Level of environmental impacts

Evaluation Criteria – Livability impacts

Category #5 – Accessibility

Evaluation Criteria – Meets or moves in the direction of the access spacing standards

Evaluation Criteria – Supports the development of a complimentary local circulation network that minimizes local travel demand through the interchange and maintains or improves access to the marina.

Based on the criteria outlined above, an evaluation matrix for each concept was created. These matrices are contained within the Technical Appendix. A summary of the qualitative screening process is provided in Table 12.3-10 below. (Note: In general, a + indicates the interchange concept is positively meeting the basic parameters of the evaluation criterion, a - indicates the interchange concept is not meeting the basic parameters of the evaluation criteria, and a 0 indicates the interchange concept is neither positively nor negatively meeting the basic intent of the evaluation criterion. See the Technical Appendix for more detailed information about the scoring criteria).

Table 12.3-10 Summary of Qualitative Screening Process

Evaluation Criteria	Concept														
	#1a	#1b	#2	#3	#4	#5	#6	#7	#8a	#8b-e	#9	#10	#11	#12	#13
Operations	+	+	+	+	+	+	-	+	+	+	+	-	+	-	+
Non-Vehicular Travel	+	+	0	0/+	0	0	0	+	+	+	+	+	+	-	+
ROW Impacts	-	-	+	0/	-	+	+	-	-	-	0	-	-	0	0
Cost	-	-	-	-	-	-	-	-	-	-	-	-	-	0	-
Construction Feasibility	-	-	-	-	-	-	-	-	-	-	-	-	-	+	+
Environmental Impacts	0	0	+	+	+	-	+	0	0	0	0	+	0	+	+
Livability Impacts	-	+	+	+	+	+	+	-	+	+	+	-	-	+	+
Access Spacing	0	0	+	+	+	+	-	0	+	+	0	-	+	-	+
Local Circulation	+	+	-	+	-	-	+	-	+	+	+	+	+	+	+

Based on this qualitative screening process, a number of concepts were eliminated from consideration. A summary of these findings is provided below.

12.3.632(1) Concepts with Significant Constructability Challenges or Fatal Flaws

Through the evaluation process, the following concepts were deemed to have significant constructability challenges or fatal operational flaws. As such, these concepts were not recommended for further evaluation.

- Concepts #1a and #4 would require a US 730 underpass widening adjacent to the railroad. A preliminary assessment from ODOT indicates that it may not be feasible to make this connection due to the way the bridge is constructed. Access to/from Brownell Boulevard is also limited.
- Concept #2 would have a constructability challenge associated with ramp length and grades needed to develop the direct-connect access ramp to I-82 southbound. This concept also cuts off Brownell Boulevard from US 730.
- Concept #5 cannot be realistically constructed as the underpass associated with the POE exit road would conflict with the Brownell irrigation ditch. This concept also cuts off Brownell Boulevard from US 730.
- Concepts #6, #10, and #12 are operationally challenged, have some significant physical constraints, and don't address the intersection spacing issues between Brownell Boulevard and the southbound ramp terminal.

12.3.632(2) Concepts with Cost, Policy, and Right-of-Way Constraints

Through the evaluation process, the following concepts were deemed to have significant cost, policy, and right-of-way constraints. As such, these concepts were not recommended for further evaluation.

- The freeway exit ramp serving the POE in Concept #1b would necessitate a complete reconstruction of the POE that may not be possible given the need to accommodate acceptable ramp grades and truck queuing lanes.
- Concept #7 would require a complete widening of the Umatilla River overpass while other loop ramp concepts would only require a partial widening. This coupled with the need for a new US 730 overpass bridge, a railroad overpass bridge widening, and POE reconfiguration would be a costly concept with minimal operational and access management benefits.
- Concept #8a would funnel a large amount of truck and vehicular traffic through US 730/Eisele Drive intersection, necessitating a large widening to this intersection.
- Concept #11 would be the most expensive concept with the split diamond and the need to widen both sides of the Umatilla River overpass.

Based on these findings and feedback from the PAC and TAC, Concepts 3, 8b/c/d/e, 9, and 11 were moved forward for detailed evaluation. These concepts are shown in *Figures 12.3-12 through 12.3-21*.



R:\0001\883112\mxd\883112_022\hwy_730\04\092710\final\map\lwp\lwp_41_12\092010_022513_AW_mxd.mxd, 09/29/10

PRELIMINARY COPY
INFORMATION ONLY



I-82/US 730 INTERCHANGE AREA
MANAGEMENT PLAN
CONCEPT 3

FIGURE
12.3-12





PRELIMINARY COPY
INFORMATION ONLY



I-82/US 730 INTERCHANGE AREA
MANAGEMENT PLAN
CONCEPT 8c

FIGURE
12.3-15

R:\0001863-12_12\mbsa_022-hwy_230\04\022710\final\AMP 12.03_6-4_12.02.2010.9.30.13 AM.mxd, P00995



R:\0001\883112\mxd\883112_022\hwy_730\092710\final\AMP\11.dwg, 6/6, 12/8/2010 9:43:15 AM, 10/20/2010 10:09:55

PRELIMINARY COPY
INFORMATION ONLY



I-82/US 730 INTERCHANGE AREA
MANAGEMENT PLAN
CONCEPT 8e

FIGURE
12.3-17



PRELIMINARY COPY
INFORMATION ONLY

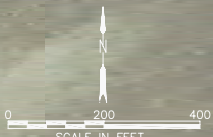

**I-82/US 730 INTERCHANGE AREA
MANAGEMENT PLAN
CONCEPT 9**

**FIGURE
12.3-18**





R:\0001\853-12\mxd\853-hwy 730\04\092710\final\MP Lanes & S1_12\092010\8-30-14_AK_mms\mms.dwg

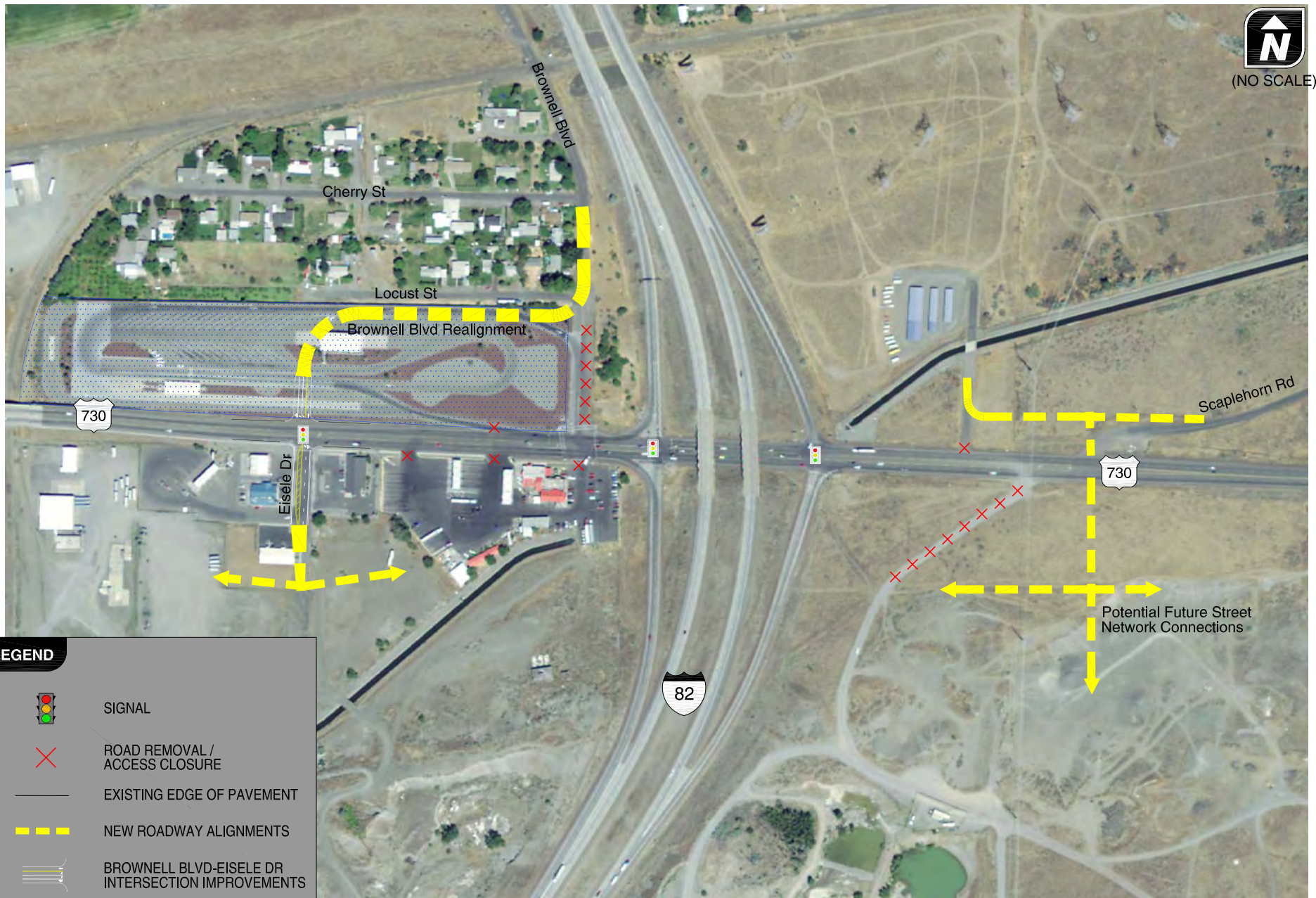

(NO SCALE)



LEGEND

-  SIGNAL
-  ROAD REMOVAL / ACCESS CLOSURE
-  EXISTING EDGE OF PAVEMENT
-  NEW ROADWAY ALIGNMENTS
-  BROWNELL BLVD-EISELE DR INTERSECTION IMPROVEMENTS

CONCEPT 13
I-82/US 730 INTERCHANGE AREA
UMATILLA, OREGON

FIGURE

Figure 12.3-20

H:\profile\10369 - I-82 US 730 IAMP\dwgs\figs\IAMP\Section7.dwg Sep 26, 2011 - 9:39am - nfooster Layout Tab: 6-9



(NO SCALE)



H:\profile\110369 - I-82 US 730 IAMP.dwg\figs\IAMP\7-1b.dwg Sep 26, 2011 - 9:43am - nfooster Layout Tab: 6-10

**RELOCATED POE AND NECESSARY ACCESSORY WEIGHING FACILITIES
UMATILLA, OREGON**

CONCEPT 13

FIGURE

Figure 12.3-21

12.3.633 Detailed Quantitative Evaluation of Selected Concepts

A more detailed evaluation was performed of the concepts remaining after the basic qualitative screening process was completed. This analysis consisted of quantitative operational and cost evaluations. *A more detailed description of this evaluation process may be found in the I-82/US 730 IAMP Technical Appendix.*

12.3.634 Transportation Operations Analysis of Selected Concepts

A transportation operations analysis was performed on the remaining concepts according to the methodologies and standards previously outlined in Section 12.3.400, with one exception: concepts that completely reconfigure the interchange (e.g. Concepts 3 and 9) must meet the more stringent volume-to-capacity ratio of 0.70 or better standard from the Oregon *Highway Design Manual* (HDM, Reference 6).

There are some common results between all concepts. The US 730/Umatilla River Road and US 730/US 395-Devore Road intersections are forecast to operate above their applicable standards. This is consistent with the future conditions analysis described in Section 12.3.500. Neither intersection was addressed by these concepts due to their distance from the I-82 ramp terminals. The unsignalized US 730/Scaplehorn Road and US 730/Bucks Lane intersections are forecast to operate with high delays for the stop-controlled side-street approaches. However, both are forecast to operate well under the applicable v/c ratio standard of 0.90 due to the relatively low volumes that are forecast to utilize those approaches.

The following subsections summarize the highlights of this analysis for each concept.

12.3.634(1) Concept 3

In Concept 3, the reconfigured I-82 Southbound ramp terminal will require dual left-turns from the Southbound off-ramp onto US 730. The dual left-turn lanes will allow the intersection to meet the HDM v/c standard and will help prevent vehicular queues from stacking back into the curve of the loop ramp. Relocating the POE would likely remove the need for dual left-turns, although they would significantly enhance its ability to accommodate long-term growth.

12.3.634(2) Concepts 8b/c/d/e

Concepts 8b and 8c will require that the I-82 Southbound off-ramp be widened from its existing configuration to include an exclusive left-turn lane in addition to the existing through/left-turn lane.

The additional lane will help prevent vehicles from stacking back on the off-ramp to the mainline of the freeway. This lane is necessitated by the shift of truck volumes from the right-turn lane to the through/left-turn lane since the POE is in a new location south of US 730 and accessed from the I-82 Southbound on-ramp. Concepts 8d and 8e may also warrant this lane to reduce the potential for queue spillback towards the mainline of the freeway. Assuming this lane is in place, the capacity is increased by approximately ten percentage points due to the removal of truck traffic from the US 730 ramp terminal.

12.3.634(3) Concept 9

Similar to Concept 3, this concept would reconfigure the I-82 Southbound ramp terminal. However, under Concept 9, truck traffic bound for the POE is provided with its own off-ramp that becomes a third westbound lane onto US 730 feeding directly into the POE. Since this traffic is removed from the ramp terminal intersection, dual left-turn lanes onto US 730 are not needed in order to meet the HDM v/c ratio standard.

12.3.634(4) Concept 11

Several variations of this concept were discussed. The first variation involves the US 730/ Eisele Drive-POE access intersection as either a roundabout or a full access traffic signal. The second variation is the connection from the POE underneath US 730 to Eisele Drive and whether this is needed or not. The results indicate that removing this underpass connection does not significantly affect operations at the traffic signal. However, a single-roundabout would be sufficient assuming that this underpass is in place. If the underpass is not in place, then a double-lane roundabout would be required due to the introduction of the truck traffic exiting the POE.

12.3.634(5) Concept 13

Under this scenario, southbound truck traffic would no longer exit I-82 at the US 730 interchange to access the POE. This would result in a significant reduction in truck volumes on portions of US 730 and at the US 730/Brownell Boulevard intersection. Relocating the Brownell Boulevard intersection to increase the spacing from the I-82 Southbound ramp terminal would still likely be necessary in order to prevent queues from spilling back in front of the ramp terminal.

12.3.635 Cost

Preliminary cost estimates were prepared for each concept. The project team developed the construction cost estimates, while ODOT prepared approximate right-of-way (ROW) estimates. These estimates are preliminary and subject to change as the concepts move into more detailed development. Table 12.3-11 provides a summary of the total cost estimate for each concept. More detailed information on the cost estimates may be found in the Technical Appendix.

Table 12.3-11 shows that concepts that relocate the POE within the existing interchange area (i.e. Concepts 3 (total) and 8b/c/d/e) are generally anticipated to have the highest costs. Concepts 3 (short-term and original) and 9 are estimated to have the lowest costs. The short-term phase of Concept 3 with the POE relocation is expected to cost slightly more, approximately \$1.5 million, than the original Concept 3 due to additional ramp construction work that would be necessary to allow for the future relocation of the POE. Concepts 8d and 8e cost more than 8b and 8c due to the additional ramps that would be constructed into the POE from I-82. Concept 13's cost is slightly higher than Concepts 3 (short-term and original) and 9, but less than the other concepts.

Table 12.3-11 Preliminary Cost Estimates

Concept	Preliminary Cost Estimate		
	Construction	ROW	Total
3 (original)	\$17,600,000	\$600,000	\$18,200,000
3 (total w/ POE relocation)	\$39,800,000	\$3,500,000	\$43,300,000
3 (short-term)	\$19,100,000	\$600,000	\$19,700,000
3 (POE relocation, long-term)	\$20,700,000	\$2,900,000	\$23,600,000
8b/8c	\$24,000,000	\$2,900,000	\$26,900,000
8d	\$33,600,000	\$2,900,000	\$36,500,000
8e	\$34,600,000	\$2,900,000	\$37,500,000
9	\$18,100,000	\$2,400,000	\$20,500,000
11	\$25,100,000	\$800,000	\$25,900,000
13	\$21,100,000	\$2,200,000	\$23,300,000

After reviewing these analyses, the TAC and PAC came to the following conclusions:

- Concept 9 is not desirable given that it eliminates the westbound right-turn from US 730 onto Brownell Boulevard;
- Concept 11 has significant costs and construction challenges compared to its benefits;
- Concepts 8b/c/d/e have significant hurdles in terms of cost and the fact that FHWA will not allow any connection from the POE to US 730, thereby limiting the practicality of these concepts, especially Concepts 8b and 8c;
- Concept 3 does solve the problems this project was originally intended to address; however relocating the POE is also important for potential future economic development in the City; and
- Concept 13 addresses the existing transportation issues, while also helping the City achieve its economic development goals.

Generally the TAC and PAC supported moving forward with Concept 13. Their feedback was taken into consideration by the project steering committee when selecting the recommended improvement plan. Ultimately, the project steering committee selected Concept 13 as the preferred transportation improvement plan.

12.3.636 *Concept Development and Screening Summary*

Table 12.3-12 summarizes the reasoning for concepts being dismissed from consideration.

Table 12.3-12 Concept Development and Screening Summary

Concept	Recommended for Inclusion in the IAMP by the TAC/PAC	Final Selection/ Primary Disadvantages to Concept
1a	No	No – Constructability
1b	No	No – Constructability
2	No	No – Constructability, Circulation
3 (original)	No	No – Does not allow POE relocation
3 (w/ POE relocation)	No	No -Cost
4	No	No – Constructability
5	No	No – Constructability
6	No	No – Constructability, Capacity
7	No	No – Cost
8a	No	No – Capacity
8b	No	No – Constructability, Circulation, Cost
8c	No	No – Constructability, Circulation, Cost
8d	No	No – Constructability, Circulation, Cost
8e	No	No – Constructability, Circulation, Cost
9	No	No – Circulation
10	No	No – Constructability, Capacity
11	No	No – Constructability, Cost
12	No	No – Constructability, Capacity
13	Yes	Yes

Figures 12.3-20 and 12.3-21 (previous) show the preferred concept.

12.3.640 *Preferred Concept Detailed Capacity Analysis*

The concept screening process described above resulted in the selection of Concept 13 as the preferred improvement plan. A detailed capacity analysis of this concept is presented in Figure 12.3-22, assuming no other changes to the infrastructure network and that the existing POE site is not redeveloped.

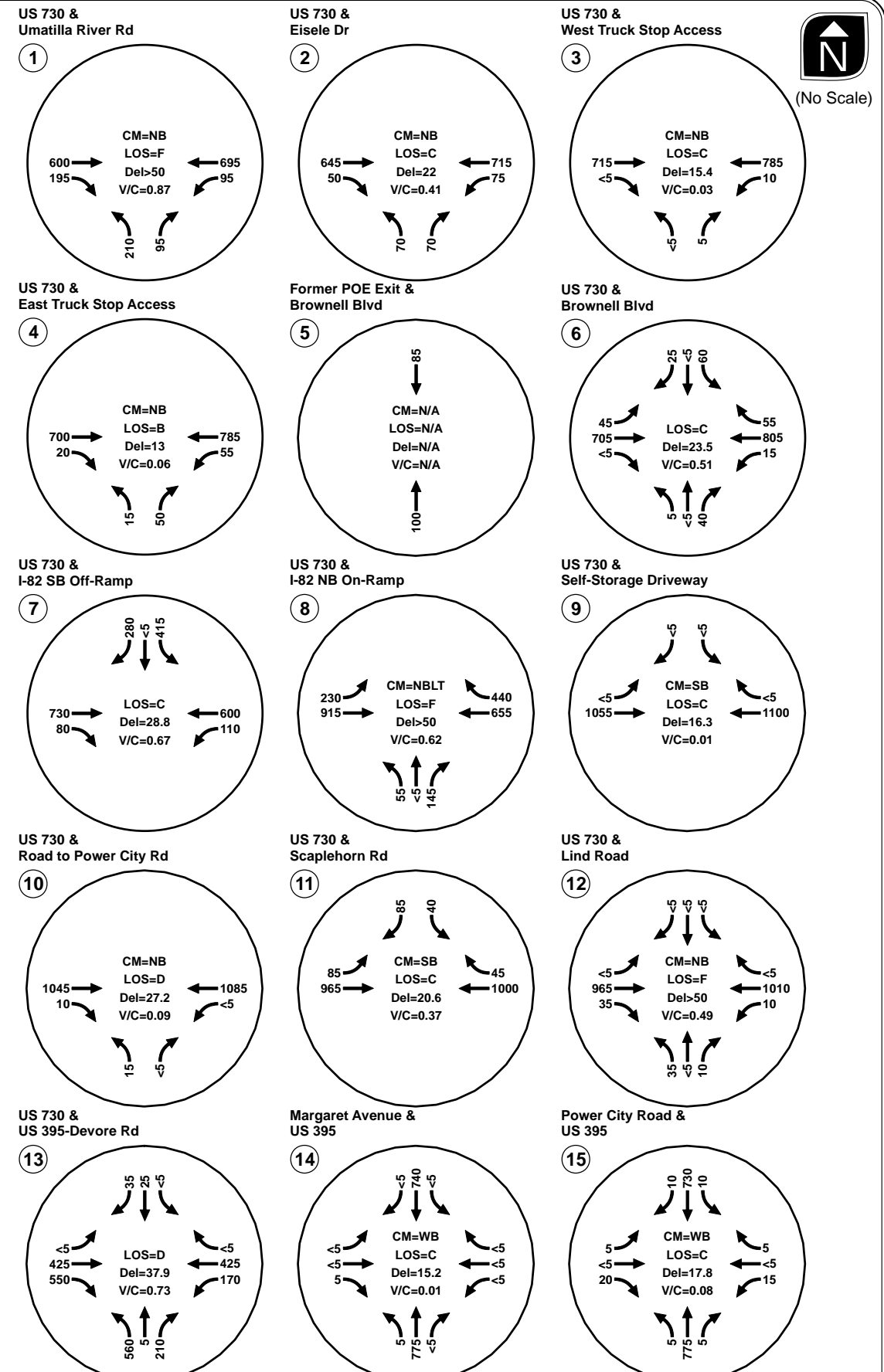
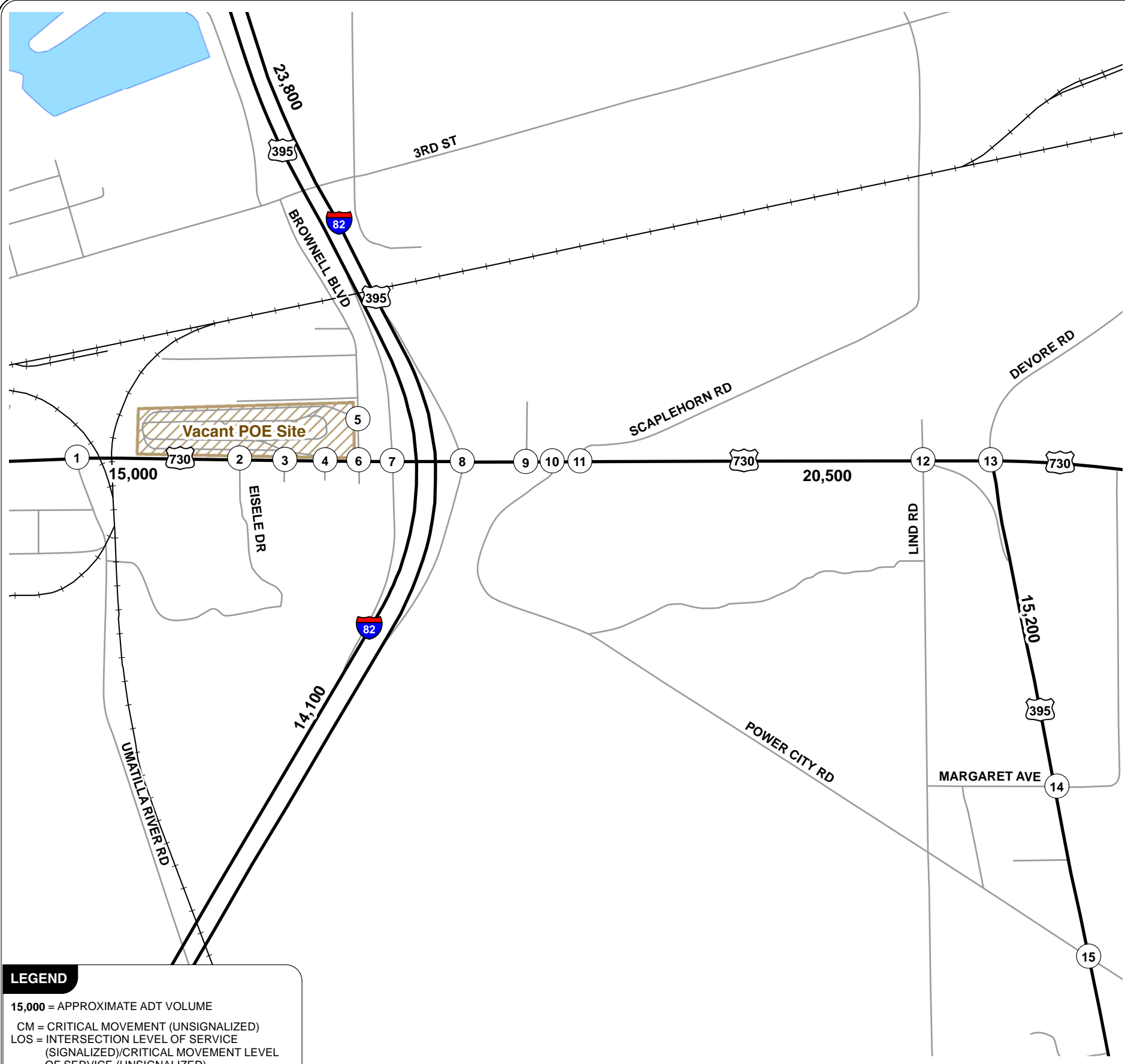

LEGEND

15,000 = APPROXIMATE ADT VOLUME

CM = CRITICAL MOVEMENT (UNSIGNALIZED)

LOS = INTERSECTION LEVEL OF SERVICE (SIGNALIZED)/CRITICAL MOVEMENT LEVEL OF SERVICE (UNSIGNALIZED)

Del = INTERSECTION AVERAGE CONTROL DELAY (SIGNALIZED)/CRITICAL MOVEMENT CONTROL DELAY (UNSIGNALIZED)

V/C = CRITICAL VOLUME-TO-CAPACITY RATIO

YEAR 2030 CONCEPT 13 OPERATIONS 30TH HIGHEST HOUR - EXISTING POE SITE VACANT UMATILLA, OREGON

H:\p\profile\10369 - I-82 US 730 IAMP\GIS\FutureConditionsOps.mxd

Table 12.3-13 compares the anticipated year 2030 traffic operations with the POE (taken from analysis summarized in Section 12.3.500) to the results shown in *Figure 12.3-22* without the POE.

Table 12.3-13 Operational Analysis Comparison

Scenario	US 730/I-82 Southbound Ramp Terminal			US 730/Brownell Boulevard		
	V/C ¹ Ratio	LOS	Delay (s)	V/C ¹ Ratio	LOS	Delay (s)
2030 Future (w/o POE relocation)	0.66	D	36.6	0.73	D	40.2
2030 Future (w/ POE relocation)	0.67	C	28.8	0.51	C	23.5

¹V/C Ratio = volume-to-capacity ratio

The table shows that traffic operations are expected to improve in the vicinity of the I-82 Southbound ramp terminal as a result of the relocation of the POE.

The results of the analysis east of I-82 are consistent with the findings discussed in Section 12.3.500 as this area is insignificantly affected by the relocation of the POE. Truck traffic passing through them will likely continue to exit I-82 at the US 730 interchange in order to travel on US 730 or US 395 as they do today.

12.3.641 Queuing

A particular concern in the vicinity of the I-82 Southbound ramp terminal is for queues of vehicles to back up from the nearby Brownell Boulevard intersection into the ramp terminal intersection. This occasionally happens and will likely occur more frequently in the future as traffic volumes increase. Removing the truck traffic associated with the POE will help alleviate queuing by not only reducing the total number of vehicles traveling through the Brownell Boulevard intersection, but also reducing the average size of those vehicles, as heavy trucks occupy more space than passenger vehicles. A queuing analysis was performed along with the traffic operations analysis. This analysis indicates that queues are not expected to exceed two vehicles at one time, which would be a length between 50 to 150 feet, depending on the types of vehicles in the queue. The latter length is about the maximum length of queue that can be accommodated in the space between the two intersections. These results are similar, though slightly improved, to those seen in the analysis of existing conditions, so the queue lengths may be underestimated in this analysis. Relocating the Brownell Boulevard intersection to increase the spacing from the I-82 Southbound ramp terminal would still likely be necessary in order to prevent queues from spilling back in front of the ramp terminal. More information about this analysis can be found in the Technical Appendix.

12.3.642 Development Potential of POE Site

In order to fully assess the potential impacts of the relocation of the POE, a separate analysis was performed assuming that site fully redevelops under its current zoning designation. The current POE site is zoned by the City of Umatilla as General Commercial (GC). This zoning designation

allows a variety of commercial uses, with limited exceptions. Given the location’s proximity to the I-82/US 730 interchange and location adjacent to US 730, it was conservatively assumed that the site would develop with commercial retail uses. Table 12.3-14 documents the project team’s assumptions for this analysis regarding potential build-out of the POE site under the GC zoning designation, along with the trip generation potential of such development. The trip generation potential for each of the land uses was calculated for the weekday p.m. peak hour using the 8th Edition of *Trip Generation*, published by the Institute of Transportation Engineers. All trip ends in Table 12.3-14 have been rounded to the nearest five.

Table 12.3-14 POE Site Redevelopment and Trip Generation Potential

Land Use	Size (Sq. Ft.)	Weekday Daily Trips	Weekday PM Peak Hour Trips		
			Total	In	Out
Shopping Center		6,810	590	290	300
<i>Pass-By Trips</i>	158,560	2,320	200	100	100
Total Net New Trips		4,490	390	190	200

As Table 12.3-14 shows, this level of development would be expected to generate approximately 6,810 trips on an average weekday, with 4,490 of those trips being new to the transportation system and approximately 390 net new trips (190 in and 200 out) during the weekday p.m. peak hour.

12.3.642(1) *Traffic Operations*

The new trips shown in Table 12.3-14 are assigned to the surrounding roadway network based on existing traffic patterns and attractions. These volumes are added to the traffic volumes from *Figure 12.3-22* in order to estimate the impacts that redevelopment of the POE site would have on the surrounding roadway system. In conducting this analysis, it is assumed that Brownell Boulevard is realigned to access US 730 across from Eisele Drive at a signalized intersection as part of the redevelopment of the site, with dual southbound left-turns and a shared through/right-turn lane from Brownell Boulevard onto US 730 provided. It is also assumed that access to properties on the south side of US 730 is provided via a backage road with a connection to Eisele Drive and that Eisele Drive has a dedicated left-turn lane and a shared through/right-turn lane for northbound traffic turning left onto US 730. The US 730 approaches would be configured as they are today, except that an eastbound left-turn lane would also be provided.

Figure 12.3-23 shows the results of the traffic operational analysis for the year 2030 assuming that the POE is relocated and that the site it currently occupies is redeveloped as shown in Table 12.3-14. The analysis reveals that the realigned Brownell Boulevard-Eisele Drive intersection with US 730 would operate just below the OHP mobility standard of a v/c ratio of 0.85, assuming the lane configurations described above. The interchange ramp terminals are also forecast to meet the applicable OHP mobility standard.



(No Scale)

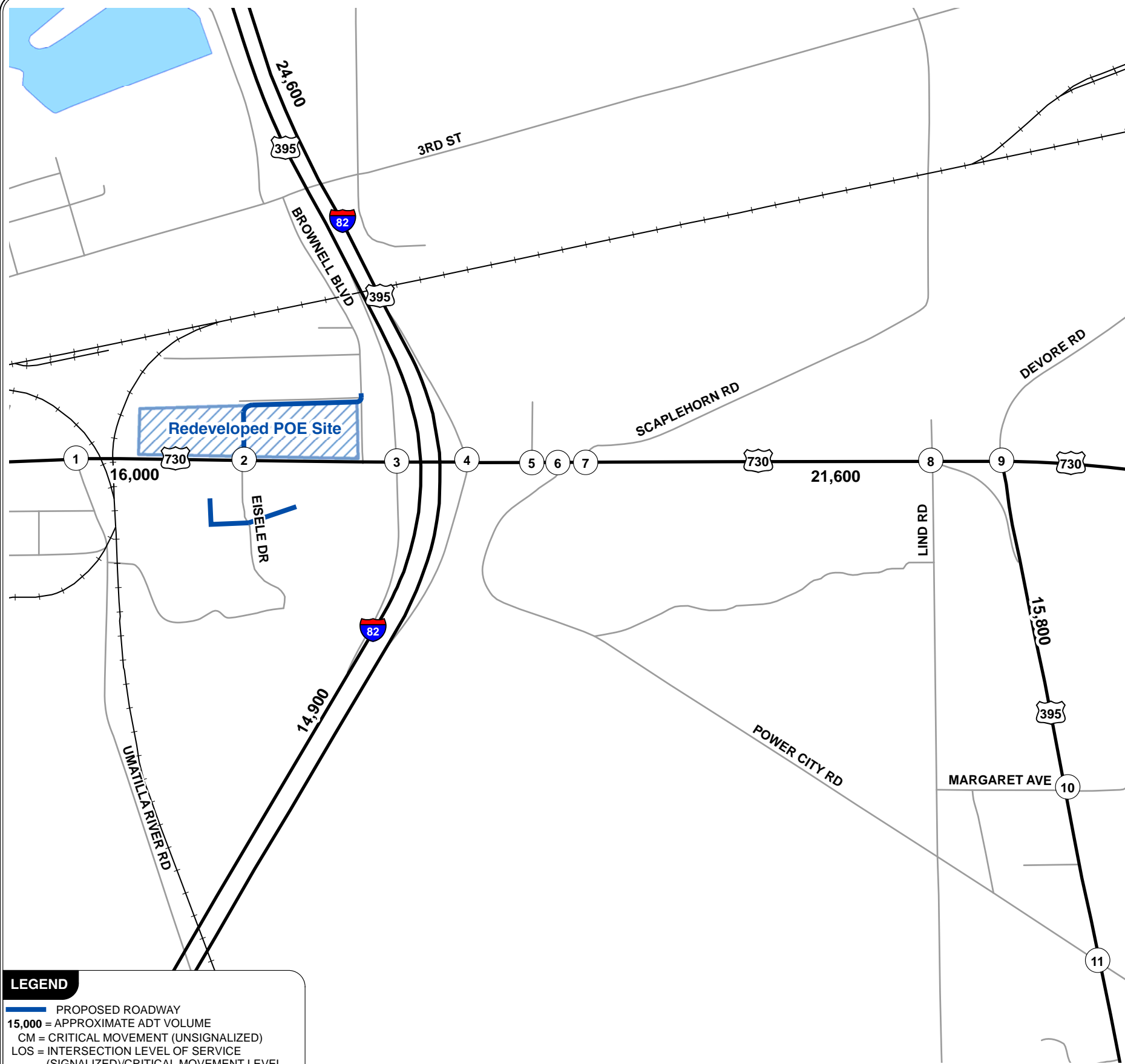

US 730 & Umatilla River Road

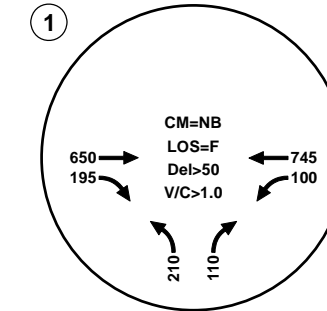

US 730 & Eisele Dr-Brownell Blvd

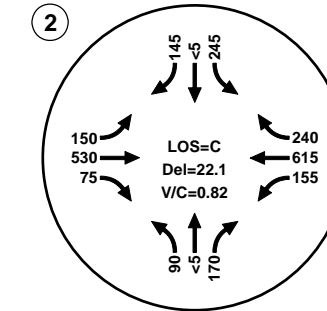

US 730 & I-82 SB Off-Ramp

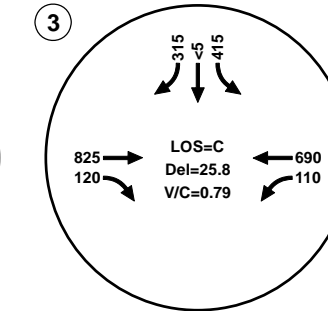

US 730 & I-82 NB On-Ramp

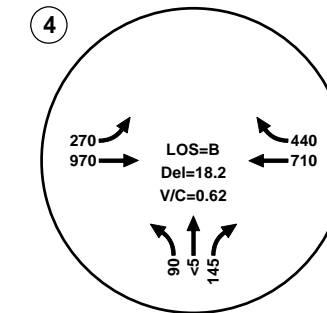

US 730 & Self-Storage Driveway

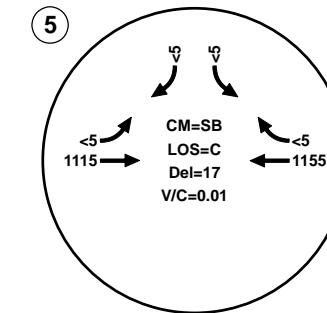

US 730 & Road to Power City Road

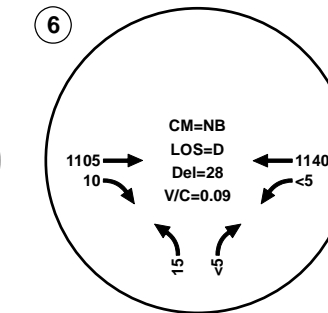

US 730 & Scaplehorn Road

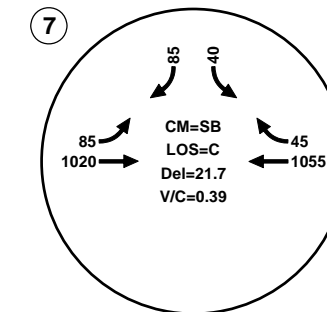

US 730 & Lind Road

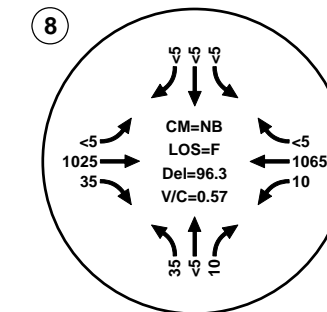

US 730 & US 395-Devore Road

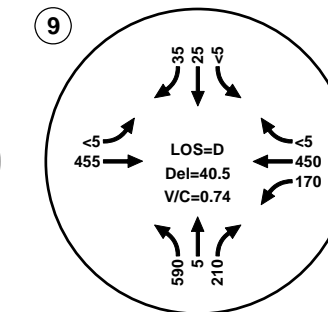

Margaret Avenue & US 395

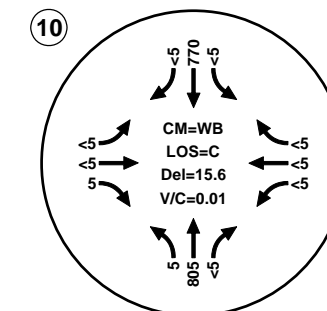

Power City Road & US 395

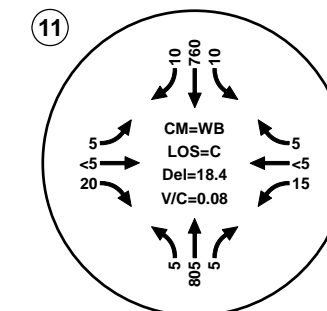

LEGEND
 PROPOSED ROADWAY
 15,000 = APPROXIMATE ADT VOLUME
 CM = CRITICAL MOVEMENT (UNSIGNALIZED)
 LOS = INTERSECTION LEVEL OF SERVICE (SIGNALIZED)/CRITICAL MOVEMENT LEVEL OF SERVICE (UNSIGNALIZED)
 Del = INTERSECTION AVERAGE CONTROL DELAY (SIGNALIZED)/CRITICAL MOVEMENT CONTROL DELAY (UNSIGNALIZED)
 V/C = CRITICAL VOLUME-TO-CAPACITY RATIO

YEAR 2030 CONCEPT 13 OPERATIONS
 30TH HIGHEST HOUR - EXISTING POE SITE REDEVELOPED
 UMATILLA, OREGON

FIGURE

H:\profiles\10369 - I-82 US 730 IAMP\GIS\FutureConditionsOps.mxd

12.3.650 East Side of Interchange Improvements

All of the concepts considered included a common set of improvements to be made to the east of the I-82/US 730 interchange. The primary purpose of these improvements is to improve local circulation and access spacing along US 730. The geography of the area precludes moving the Scaplehorn Road access east to better meet access spacing standards. Instead, as development occurs north of US 730 on the east side of the interchange, the perpendicular section of the Scaplehorn Road approach to US 730 will be lengthened to approximately 200 feet to provide stacking distance for vehicles turning onto US 730. Scaplehorn Road will also be extended to serve as a frontage road that provides access for these properties. Similarly, as development occurs on the south side of US 730 on the east side of the interchange, a local street network that accesses US 730 at the Scaplehorn Road intersection will need to be constructed. These circulation and access connections are shown in *Figure 12.3-20*.

12.3.660 Pedestrian Improvements

Pedestrian facilities along US 730 in the study are limited to the south side of US 730 on the west side of the interchange. Sidewalks along with curb and gutter will be constructed on the north side of US 730 from the interchange to the bridge over the Umatilla River as development occurs and/or roadway improvements are made. They will also be constructed on both sides of US 730 east of the interchange to the US 395 intersection as development occurs and/or roadway improvements are made.

12.3.700 INTERCHANGE AREA MANAGEMENT PLAN

The I-82/US 730 IAMP provides a transportation improvement plan and an Access Management Plan (AMP). The transportation improvement plan includes interchange and local circulation improvements, as well as a phasing schedule. The AMP contains an access management plan and documents the justification for the necessary deviations to ODOT's access management standards.

Through adoption by the City of Umatilla, Umatilla County, and ODOT, future development located within the Interchange Management Study Area (IMSA) will be required to make circulation and access improvements, as identified in this plan. Implementation of the IAMP is expected to preserve the functional integrity of the interchange over time and ensure viable access to existing and future land uses. Finally, the action items contained within the implementation plan (Section 12.3.800) will ensure proper coordination between the various stakeholders and that the IAMP remains a dynamic long-term planning tool.

12.3.701 Transportation Improvement Plan Overview

A comprehensive transportation improvement plan including a local circulation and access plan within the interchange management study area (IMSA) was developed based on the concept screening and evaluations outlined in Section 12.3.600. *Figures 12.3-24* and *12.3-25* illustrate the transportation improvement plan. This plan includes the relocation of the Port of Entry (POE) to a new location along I-82, alignments of new roadways and intersections, and modifications to existing roadways and intersections. Each transportation improvement identified in the two figures is described in Table 12.3-15. *Figure 12.3-26* illustrates the lane

configurations and traffic control devices associated with the improvement plan. This table also contains preliminary cost estimates for the improvements.







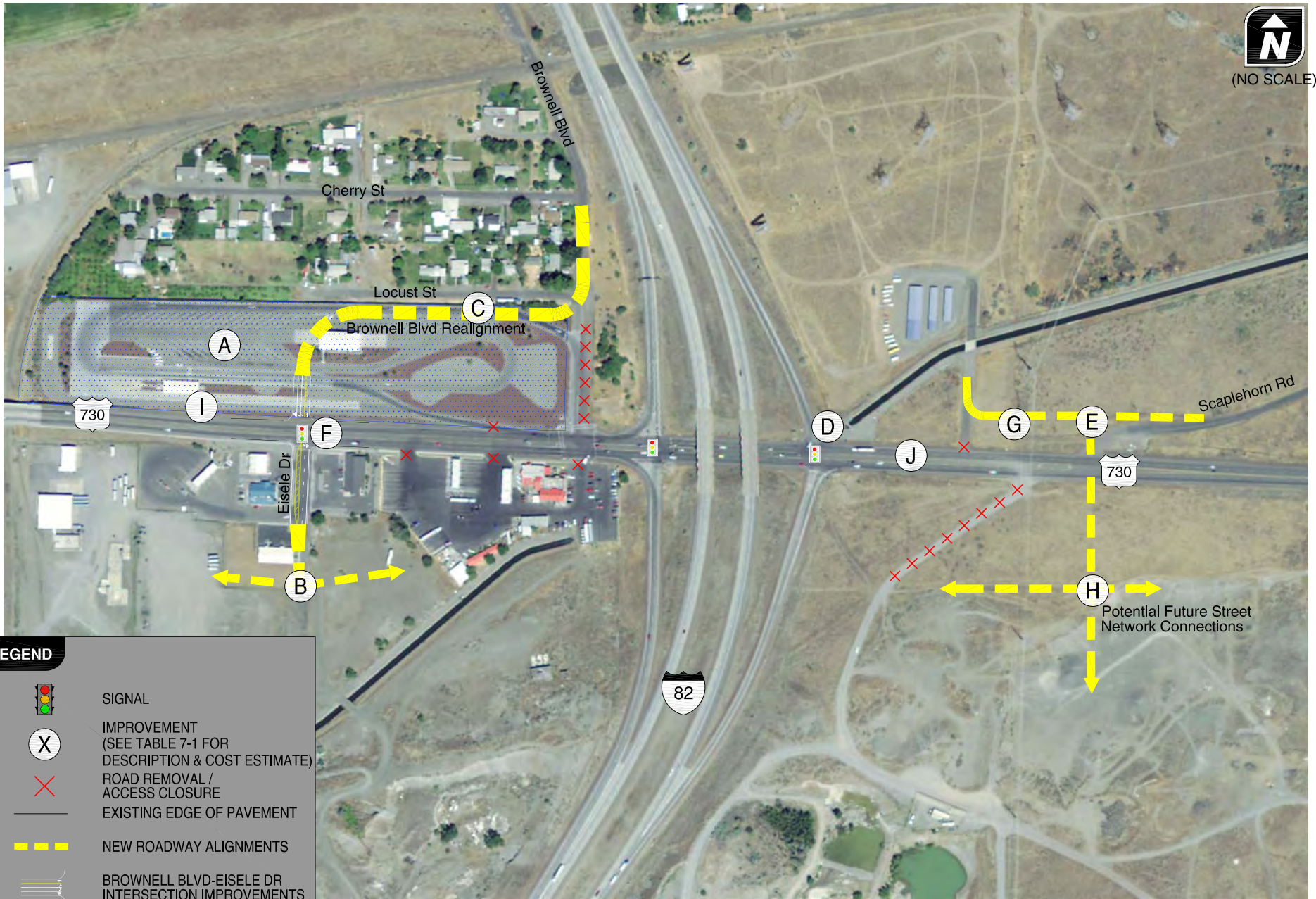

(NO SCALE)

H:\profile\10369 - I-82 US 730 IAMP\dwgs\figs\IAMP\Section7.dwg Sep 28, 2011 - 4:31pm - nfooster Layout Tab: 7-1



LEGEND

-  SIGNAL
-  IMPROVEMENT
(SEE TABLE 7-1 FOR DESCRIPTION & COST ESTIMATE)
-  ROAD REMOVAL / ACCESS CLOSURE
-  EXISTING EDGE OF PAVEMENT
-  NEW ROADWAY ALIGNMENTS
-  BROWNELL BLVD-EISELE DR INTERSECTION IMPROVEMENTS

**TRANSPORTATION IMPROVEMENT PLAN
I-82/US 730 INTERCHANGE AREA
UMATILLA, OREGON**

FIGURE



(NO SCALE)



H:\profile\110369 - I-82 US 730 IAMP.dwg\figs\IAMP\7-1b.dwg Sep 28, 2011 - 4:35pm - nfooster Layout Tab: Layout1

**IAMP TRANSPORTATION IMPROVEMENT PLAN
RELOCATED POE AND NECESSARY ACCESSORY WEIGHING FACILITIES
UMATILLA, OREGON**





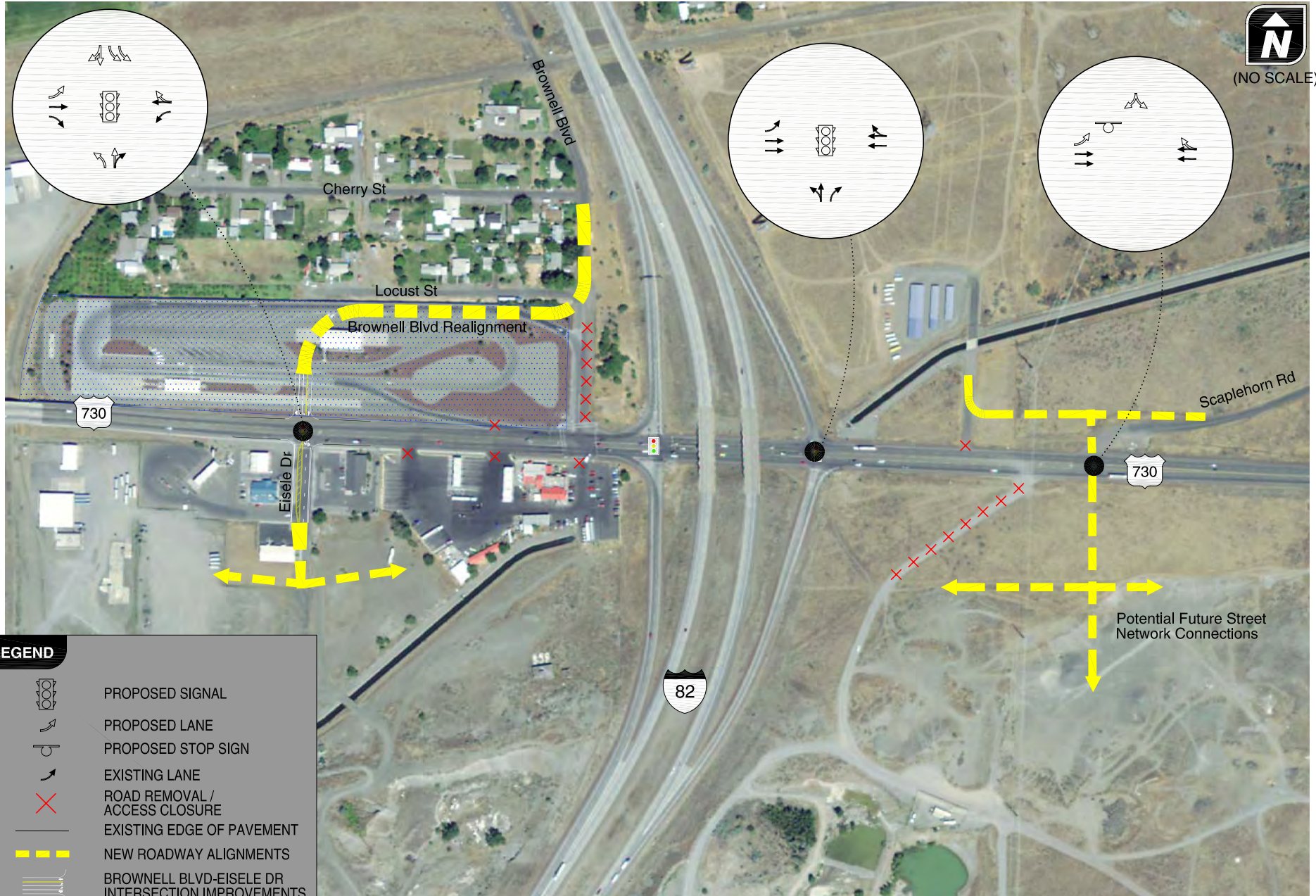



FIGURE

H:\profile\10369 - I-82 US 730 IAMP\dwgs\figs\IAMP\Section7.dwg Sep 28, 2011 - 4:31pm - nfooster Layout Tab: 7-2



(NO SCALE)

LEGEND

-  PROPOSED SIGNAL
-  PROPOSED LANE
-  PROPOSED STOP SIGN
-  EXISTING LANE
-  ROAD REMOVAL / ACCESS CLOSURE
-  EXISTING EDGE OF PAVEMENT
-  NEW ROADWAY ALIGNMENTS
-  BROWNELL BLVD-EISELE DR INTERSECTION IMPROVEMENTS

**TRANSPORTATION IMPROVEMENT PLAN LANE CONFIGURATIONS AND TRAFFIC CONTROL DEVICES
I-82/US 730 INTERCHANGE AREA
UMATILLA, OREGON**

FIGURE

Table 12.3-15 IAMP Transportation Improvements

	Improvement/Description	Trigger for Improvement	Estimated Cost¹	Potential Funding Source
A	Relocate the POE to the I-82 corridor (see Figures 12.3-24 and 12.3-26) and construct a permanent weigh station on US 730 (location to be determined via a separate study) and a temporary truck scale on US 395 (location to be determined via a separate study).	Relocation of POE	\$21M	STIP
B	Construct a new backage road accessed via Eisele Drive to provide access and circulation for properties along the south side of US 730.	Redevelopment of parcels along the south side of US 730.	\$0.7M	PDF
C	Realign Brownell Boulevard to connect to US 730 across from Eisele Drive (exact alignment of Brownell Boulevard to be determined based on future development or City project).	The need to realign Brownell Boulevard will be evaluated in a TIS when 95th-percentile westbound queues (at the existing US 730/Brownell Boulevard intersection) exceed two vehicles and spillover into the I-82 Southbound ramp terminal. Based on a sensitivity analysis of traffic operations, this condition is forecast to occur when the total entering volume at the current intersection exceeds approximately 1,950 vehicles.	\$0.65M	PDF
D	Signalize the I-82 Northbound ramp terminal.	When signal warrants are met.	\$0.3M	STIP PDF
E	Realign Scaplehorn Road to provide a longer perpendicular section.	Redevelopment of parcels along the north side of US 730.	\$0.15M	PDF
F	Signalize the US 730/Eisele Drive/Brownell Road intersection.	When Brownell Boulevard is realigned and when signal warrants are met.	\$0.3M	PDF
G	Extend Scaplehorn Road west to create a frontage road.	Redevelopment of parcels along the north side of US 730.	\$0.2M	PDF
H	Develop a network of local streets that align across from the new Scaplehorn Road intersection.	Redevelopment of parcels along the south side of US 730.	TBD ²	PDF
I	Construct sidewalks on the north side of US 730 from the Umatilla River bridge to the I-82 Southbound ramp terminal	Redevelopment of parcels along the north side of US 730 and roadway improvement projects along US 730	\$0.4M	STIP City PDF
J	Construct sidewalks on both sides of US 730 from the I-82 Southbound ramp terminal to US 395	Redevelopment of parcels and roadway improvement projects along US 730	\$2.0M	STIP City PDF

¹ Includes preliminary construction and right-of-way cost estimates based on 2010 dollars.

² Improvements to be constructed by future development.

STIP – Statewide Transportation Improvement Program
(ODOT) PDF – Private Development Funds (Private Parties)

TIS – Traffic Impact Study

The following section provides details on the major improvements identified in the Transportation Improvement Plan, including possible deviations from standards that may be required.

12.3.710 Major Improvements

Relocating the existing POE is the central component of this plan. As was discussed in greater detail in Section 12.3.600, the POE in its current location serves as a gateway to Umatilla. The amount of truck traffic it brings into the area during peak harvest times is a significant factor behind the existing traffic issues at the interchange. It was determined that relocating the POE would likely cost as much or less than modifying the interchange to continue to accommodate the POE in the long-term. As such, the plan identifies a potential relocation site for the POE, shown in *Figure 12.3-25*, south of the I-82/US 730 interchange along the I-82 corridor. This location would allow for the POE to be rebuilt with a larger footprint capable of accommodating more overnight truck parking than the current location allows. The relocated POE would have dedicated on- and off-ramps via I-82 southbound. *Figure 12.3-27* provides a detailed conceptual drawing of the relocated POE.

Given that the relocated POE would only have direct access via I-82 Southbound, this single site is no longer able to effectively serve and enforce the weigh process for trucks traveling along the US 395 and US 730 corridors. As such, this plan necessitates the development of a permanent weigh station on US 730 (somewhere west of Umatilla) and a truck scale to be used as needed along US 395 (somewhere south of US 730). The identification of sites for these facilities has not been completed as part of this process, and therefore no locations are shown. However, rough cost estimates of these facilities (based on a typical design shown in *Figure 12.3-28*) are included in the estimate shown in Table 12.3-15.

H:\profile\10369 - I-82 US 730 IAMP\dwgs\figs\IAMP\7-3.dwg Sep 28, 2011 - 4:36pm - mfcster Layout Tab: 7-3



**RELOCATED POE
CONCEPTUAL DRAWING
UMATILLA, OREGON**

FIGURE



(NO SCALE)

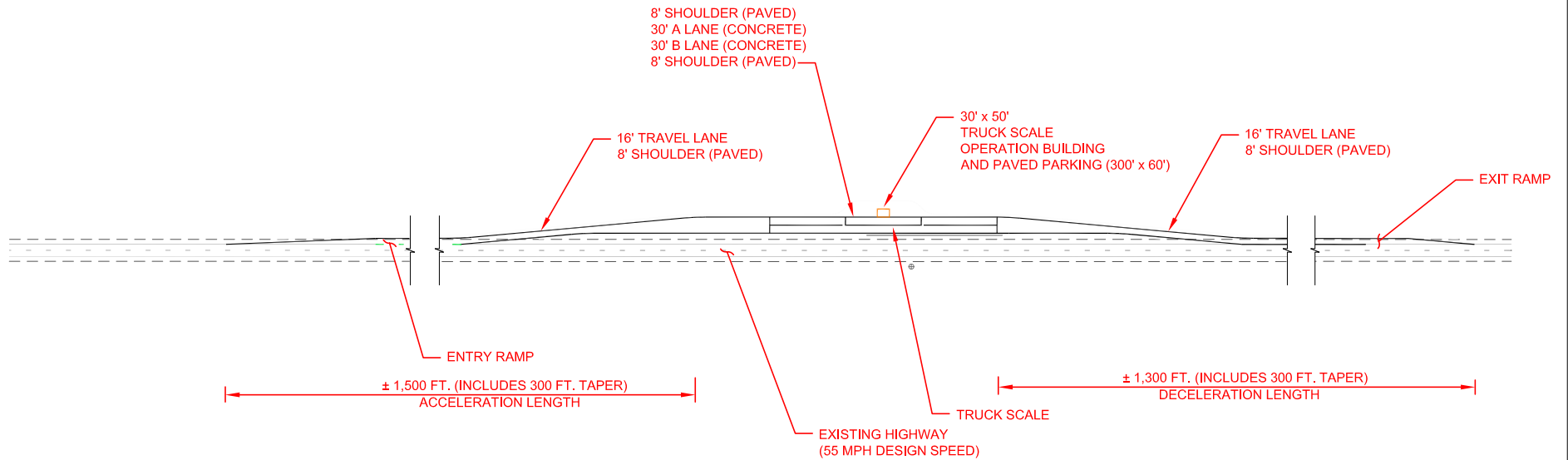

PRELIMINARY COPY
INFORMATION ONLY

DRAWING PROVIDED BY
ANDERSON-PERRY & ASSOCIATES

NOTE:
ACCELERATION AND DECELERATION
LENGTHS BASED ON AN ASSUMED
HIGHWAY DESIGN SPEED OF 55 MPH.

**TYPICAL TRUCK SCALE
CONCEPTUAL DRAWING
UMATILLA, OREGON**

FIGURE

12.3.710(1) *Brownell Boulevard*

Relocating the POE allows for Brownell Boulevard to be realigned through the site and intersect US 730 directly across from Eisele Drive. Such realignment would significantly improve the intersection spacing between Brownell Boulevard and the I-82 SB ramp terminal and move in the direction of achieving the desirable ¼-mile spacing standard. This Brownell Boulevard realignment is envisioned to occur over time, but only after the POE is potentially relocated. To ensure that the realignment occurs as envisioned, the IAMP has laid out the following steps that ODOT, the City of Umatilla, and Umatilla County should take following POE relocation:

A. ODOT and the City of Umatilla will enter into a memorandum of understanding (MOU) that establishes parameters for the sale of the POE site. Specific details of the agreement should include the following:

- 1). ODOT will go through a process to surplus the property.
- 2) Sale of the POE property will exclude the land necessary to establish the right-of-way to establish the Brownell Boulevard realignment as illustrated in *Figure 12.3-24*.
- 3) The excluded property should be sufficient to accommodate the Minor Arterial standard in the City's Transportation System Plan. This includes two 12 foot travel lanes, a 14 foot center turn lane, two 6 foot bike lanes, two 5 foot planting strips, and two 6 feet sidewalks. In addition to this cross-section, *Figure 12.3-26* illustrates the recommended Brownell Boulevard approach to US 730 based on the traffic analysis (dual southbound left-turn lanes and a shared through/right-turn lane onto US 730, with approximately 125 feet of storage for the left-turn lanes).

B. Construction of the actual Brownell Boulevard realignment will occur as part of future redevelopment of the POE site. A trigger point for the realignment should occur when 95th percentile westbound queues (at the existing US 730/Brownell Boulevard intersection) exceed two vehicles and spillover into the I-82 Southbound ramp terminal. Based on a sensitivity analysis of traffic operations, this condition is forecast to occur when the total entering volume at the current intersection exceeds approximately 1,950 vehicles. This is the equivalent of year 2030 traffic conditions with the POE relocated and approximately 50,000 square-feet of retail development on the current POE site.

C. After full realignment of Brownell Boulevard, the City of Umatilla will take over ownership and maintenance responsibility from Umatilla County.

12.3.710(2) *Eisele Drive and Backage Road*

To better manage access along the south side of US 730, right-of-way should be acquired as part of future redevelopment projects to the east and west of Eisele Drive. A new backage road would then be constructed to link all of the properties on the south side of US 730. This backage road will be constructed as part of future redevelopment to a Collector standard in the City's transportation system plan. This includes two 12 foot travel lanes, a 12 foot center turn lane, two 6 foot bike lanes, two 5 foot planting strips, and two 6 feet sidewalks.

The US 730/Eisele Drive intersection will be signalized with the realignment of Brownell Boulevard. At this point, or when development of the backage road occurs, whichever is first, the Eisele Drive approach should be widened to provide an exclusive left-turn lane.

12.3.710(3) I-82/US 730 Northbound Ramp Terminal

On the east side of the interchange, signalize the I-82/US 730 Northbound ramp terminal. Signalization is anticipated to be needed to accommodate peak hour travel demand from continued traffic growth at the interchange.

12.3.710(4) Scaplehorn Road and Local Circulation

The geography of the area precludes moving the Scaplehorn Road access east to better meet access spacing standards. Instead, as development occurs north of US 730 on the east side of the interchange, the perpendicular section of the Scaplehorn Road approach to US 730 will be lengthened to approximately 200 feet to provide stacking distance for vehicles turning onto US 730. Scaplehorn Road will also be extended to serve as a frontage road that provides access for these properties. Similarly, as development occurs on the south side of US 730 on the east side of the interchange, a local street network that accesses US 730 at the Scaplehorn Road intersection will need to be constructed. These circulation and access connections are illustrated in *Figure 12.3-24*.

12.3.710(5) Pedestrian Improvements

Pedestrian facilities along US 730 in the study are currently limited to the south side of US 730 on the west side of the interchange. Sidewalks along with curb and gutter will be constructed on the north side of US 730 from the interchange to the bridge over the Umatilla River as development occurs and/or roadway improvements are made. They will also be constructed on both sides of US 730 east of the interchange to the US 395 intersection as development occurs and/or roadway improvements are made.

12.3.711 Possible Exceptions/Deviations from Standards

The deviations that will be required for the near-term improvements are related to the access spacing standards outlined under Oregon Administrative Rule 734, Division 51 and the Oregon Highway Plan (OHP). These deviations are discussed in the access management subsection below.

12.3.720 Access Management Plan

Access locations within the IMSA were evaluated based on ODOT's Division 51 Access Management standards and an assessment of traffic operations and safety as described in Action 3C.3 of the 1999 Oregon Highway Plan. Accordingly, an Access Management Plan (AMP) is developed to preserve the operational integrity and safety of primary roadways (e.g. US 730) serving the interchange area, while maintaining viable access to all parcels in the IMSA. The AMP contains both a plan for actions to be taken on City and County of Umatilla roadways (i.e. SW Eisele Drive and Brownell Boulevard) and adopted into the City's and County's TSPs, respectively, and a plan, which is implemented by ODOT on state highway facilities (i.e., I-82, US 730) and adopted into the OHP as part of the facility plan.

An AMP is identified for the near-, medium-, and long-term timeframes. The overall AMP is illustrated in *Figure 12.3-29*. Justification is also provided for locations where deviations from ODOT's access management standards are necessary. Access management will be implemented as part of ODOT, City, and County project development and delivery processes or as future land use changes occur.

12.3.721 General Access Management Implementation

Under ODOT's current access management policy, the 1999 Oregon Highway Plan stipulates that the desired distance between an interchange ramp terminal and the first full approach (public or private) on the crossroad should be a minimum of 1,320 feet (¼-mile). The first right-in/right-out access should be a minimum of 750 feet from the ramp terminal. Currently there are 4 private approaches and 3 public street approaches on the west side of the interchange and 2 private and 1 public approaches on the east side within 1,320 feet of the interchange ramp terminals, as was previously documented in *Figures 12.3-7* and *12.3-8*.

12.3.722 Existing Private Approach Policy

ODOT guarantees Access Permit protection, as allowed within ORS 374.305 & 310, to all existing private accesses. Each will remain a valid access as long as the existing uses remain on property/site and there is no capital improvement project that would trigger review of the access (per OAR 734.051.0285). An access evaluation will be required when any of the following land use actions leads to a peak hour increase in 50 trips or more over the prior use, a daily increase of 500 trips or more over the prior use, or the increase represents a 20 percent or more increase in trips on a typical day/peak hour; if there is an identified safety or operational problem related to the approach; if the approach does not meet sight distance requirements; or if the daily traffic using the approach increases by 10 or more vehicles with a gross vehicle weight equal to or greater than 26,000 pounds:

Modifications to existing zoning,

Changes to plan amendment designations;

Construction of new buildings;

Increases in floor space of existing buildings;

Division or consolidation of property boundaries;

Changes in the character of traffic using the driveway/approach;

Changes to internal site circulation design or inter-parcel circulation; or

Re-establishment of a property's use (after discontinuance for four years or more that trigger a Traffic Impact Assessment as defined below) that occurs on the parcels served by the approaches.







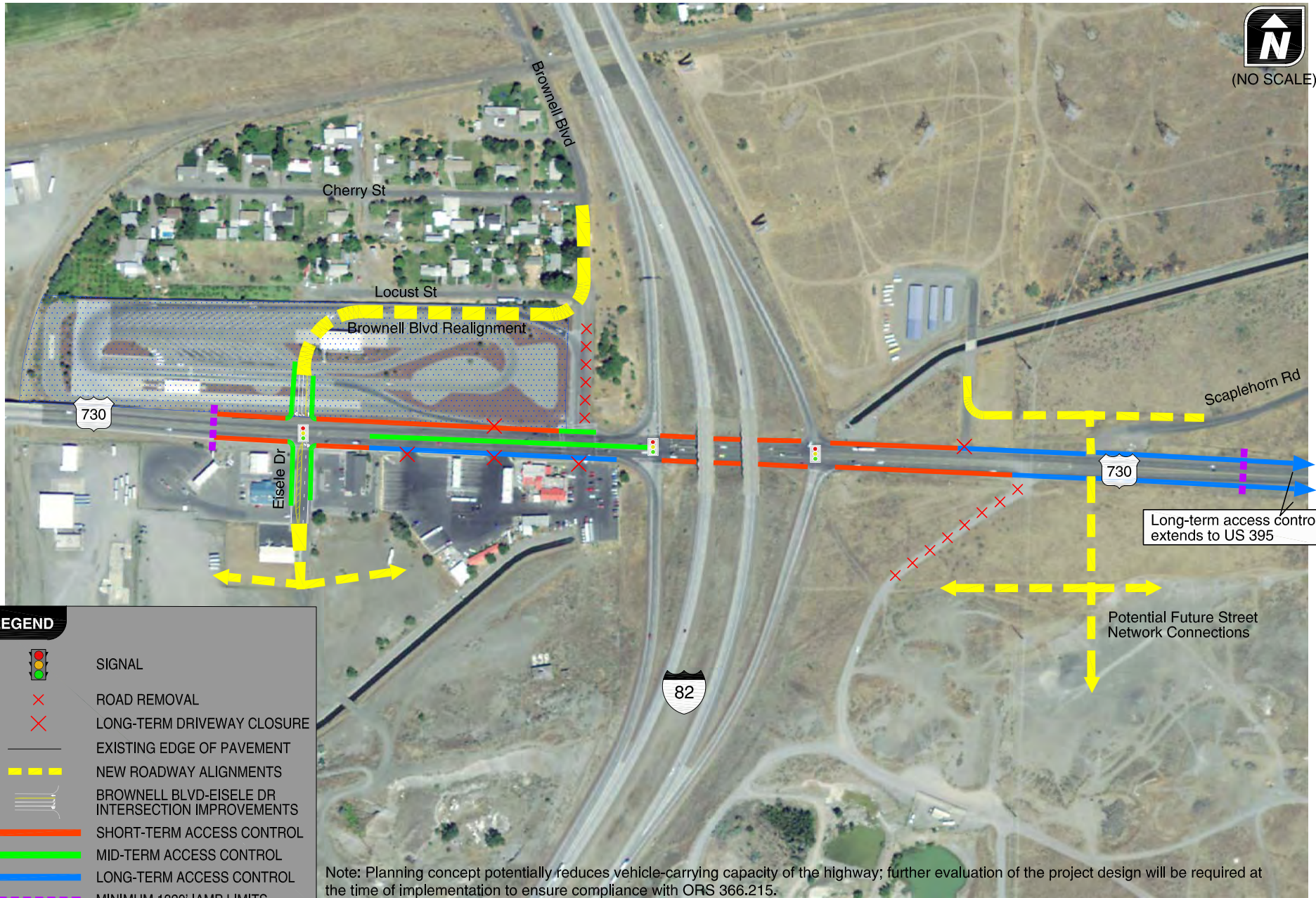





(NO SCALE)

H:\profile\10369 - I-82 US 730 IAMP\dwgs\figs\IAMP\Section7.dwg Dec 06, 2011 - 8:04am - nfooster Layout Tab: 7-5



LEGEND

-  SIGNAL
-  ROAD REMOVAL
-  LONG-TERM DRIVEWAY CLOSURE
-  EXISTING EDGE OF PAVEMENT
-  NEW ROADWAY ALIGNMENTS
-  BROWNELL BLVD-EISELE DR INTERSECTION IMPROVEMENTS
-  SHORT-TERM ACCESS CONTROL
-  MID-TERM ACCESS CONTROL
-  LONG-TERM ACCESS CONTROL
-  MINIMUM 1320' IAMP LIMITS

Note: Planning concept potentially reduces vehicle-carrying capacity of the highway; further evaluation of the project design will be required at the time of implementation to ensure compliance with ORS 366.215.

**ACCESS MANAGEMENT PLAN
UMATILLA, OREGON**

FIGURE

Figure 12.3-29

In general, the types of improvements identified for accesses within the IMSA include:

Modifying, mitigating, consolidating, or removing existing approaches pursuant to an access management plan as part of the highway project development and delivery process (OAR 734-051);

Improving traffic safety and operations by improving the local street network to provide alternate access and reduce conflict points; and,

Restricting highway access but improving local roadway access by introducing shared access, cross-over easements, and/or consolidated access when separate parcels are assembled for redevelopment, and access via collector or local streets.

The time period over which the following measures will be implemented will depend on the rate of redevelopment within the IMSA and when the transportation improvement plan projects identified previously are constructed. As each parcel redevelops, or upon capital improvement, accesses will be evaluated to determine how they will be modified in order to move in the direction of meeting the access spacing standards and long-term vision of driveway consolidation while still providing access as defined in OAR 734-051.

12.3.723 Access Management

Figure 12.3-29 illustrates the AMP for the IMSA. The AMP is divided into three time-frames: near-term, mid-term, and long-term. The near-term plan illustrates how access will be controlled with the initial construction of identified near-term improvements. After the near-term improvements are constructed, ODOT and the City could then begin implementing the mid-term plan, based upon parcels redeveloping or safety and operational needs warranting access restrictions. The long-term plan would be implemented once the long-term improvements are constructed. The following is a description of the AMP for each major roadway.

12.3.723(1) US 730

The AMP for US 730 is primarily focused on not allowing new private accesses to the highway within ¼-mile of the interchange ramps. It also focuses on minimizing existing approach connections over time through closures, and consolidations, supported by alternate access provided via a backage road connecting to Eisele Drive. This plan will be implemented in the near-, mid-, and long-term time-frames as outlined in *Figure 12.3-29*. In the mid-term, Brownell Boulevard will be realigned across from Eisele Drive in order to improve access spacing and provide access to the potential future redevelopment of the current POE site. Brownell Boulevard will be the closest full access to the interchange on the north side of US 730. In the long-term, the remaining accesses in this segment of US 730 between the interchange and Umatilla River Road may be restricted to right-in/right-out access by a raised center median that will be constructed to address future operational and/or safety issues. The existing accesses onto the south side of US 730 on the west side of the interchange may remain as right-in/right-out accesses after the backage road is constructed and until redevelopment occurs. At this time a review of the accesses will determine whether they remain.

A similar approach is taken on the east side of the interchange as well. Access points will be consolidated when possible as properties redevelop. When possible, access will be provided via public street connections, including both existing roadways and the future south side street network shown on *Figure 12.3-29*.

12.3.723(2) Eisele Drive

The access management plan for Eisele Drive is to move accesses as far south as is practical over time in order to minimize conflicts near its signalized intersection with US 730.

12.3.723(3) Brownell Boulevard

The access management plan for Brownell Boulevard is to not allow any accesses within the 250 feet of storage needed for left-turning traffic onto US 730 when it is realigned.

12.3.724 Deviations to the Division 51 Access Management Standards

A few accesses will not meet the applicable OAR Division 51 access spacing standard, and as such, deviations are required to address them. These deviations will be reviewed by the Region Access Management Engineer. Under the provisions, the Region Access Management Engineer may approve a deviation if:

- (a) Adherence to spacing standards creates safety or traffic operation problems;*
- (b) The applicant provides a joint approach that serves two or more properties and results in a net reduction of approaches to the highway;*
- (c) The applicant demonstrates that existing development patterns or land holdings make joint use approaches impossible;*
- (d) Adherence to spacing standards will cause the approach to conflict with a significant natural or historic feature including trees and unique vegetation, a bridge, waterway, park, archaeological area, or cemetery;*
- (e) The highway segment functions as a service road;*
- (f) On a couplet with directional traffic separated by a city block or more, the request is for an approach at mid-block with no other existing approaches in the block or the proposal consolidates existing approaches at mid-block; or*
- (g) Based on the Region Access Management Engineer's determination that:*
 - (A) Safety factors and spacing significantly improve as a result of the approach; and*
 - (B) Approval does not compromise the intent of these rules as set forth in OAR 734-051-0020 (Which states: The purpose of Division 51 rules is to provide a safe and efficient transportation system through the preservation of public safety, the improvement and development of transportation facilities, the protection of highway traffic from the hazards of unrestricted and unregulated entry from adjacent property, and the elimination of hazards due to highway grade intersections.)*

The following is a description of the justification for deviation for each of the public accesses requiring a deviation.

12.3.724(1) Public Access to Eisele Drive

A deviation to the access spacing requirements identified in OAR Division 51 is required at the US 730/Eisele Drive (and future Brownell Boulevard) intersection, which is located approximately 1,050 feet west of the I-82 Southbound ramp terminal, as shown in *Figure 12.3-29*. As was mentioned above, a deviation may be approved if:

(b) The applicant provides a joint approach that serves two or more properties and results in a net reduction of approaches to the highway;

Response: Eisele Drive will provide access to properties on the south side of US 730, which will facilitate the consolidation of private accesses onto US 730. Brownell Boulevard will provide access to properties on the north side of US 730, ensuring that new accesses onto US 730 are not needed.

(g) Based on the Region Access Management Engineer's determination that:

(A) Safety factors and spacing significantly improve as a result of the approach; and

(B) Approval does not compromise the intent of these rules as set forth in OAR 734-051-0020 (Which states: The purpose of Division 51 rules is to provide a safe and efficient transportation system through the preservation of public safety, the improvement and development of transportation facilities, the protection of highway traffic from the hazards of unrestricted and unregulated entry from adjacent property, and the elimination of hazards due to highway grade intersections.)

Response: This access management plan improves the existing spacing to the nearest signalized intersection and meets the intent of the Division 51 rules as it reduces vehicle turning conflicts within the interchange access management area, and protects the flow of highway traffic traveling to/from the interchange by facilitating the consolidation of accesses.

12.3.724(2) Public Access to Scaplehorn Road

A deviation to the access spacing requirements identified in OAR Division 51 is required at the US 730/Scaplehorn Road (and future south side circulation road) intersection, which is located approximately 800 feet east of the I-82 Northbound ramp terminal, as shown in *Figure 12.3-29*. As was mentioned above, a deviation may be approved if:

(b) The applicant provides a joint approach that serves two or more properties and results in a net reduction of approaches to the highway;

Response: Scaplehorn Road provides access to properties on the north side of US 730, which will facilitate the consolidation of private accesses onto US 730 and ensure that new accesses are not needed. The new circulation roadway will provide access to properties on the south side of US 730, consolidating existing access and ensuring that new accesses onto US 730 are not needed.

12.3.800 IMPLEMENTATION PLAN

This section describes the IAMP implementation strategy, which includes an I-82/US 730 Interchange Function and Policy Definition and Management Area. The Implementation Plan also includes adoption and monitoring procedures that will ensure transportation improvements are constructed and funded as development occurs and that the improvement plan is updated as needed over time.

To ensure that the IAMP remains dynamic and responsive to changes to the adopted land use and transportation plans, the City of Umatilla, Umatilla County, and ODOT should, at a minimum:

- Amend their respective Transportation System Plans and Comprehensive Plans;
- Amend the Oregon Highway Plan (OHP);
- Codify and map an IAMP Management Area that defines the area wherein regulations and requirements associated with protecting the interchange apply;
- Coordinate planning activities pursuant to the Transportation Planning Rule (OAR 660-012);
- Review the IAMP and mobility standards for the interchange prior to adopting local plan amendments.

12.3.810 Plan Elements

In addition to adoption of the IAMP described in Section 12.3.700, implementation of the I-82/US 730 IAMP requires adoption of an “Interchange Function and Policy Definition” and IAMP Management Area.

12.3.811 Interchange Function and Policy Definition

The City of Umatilla and Umatilla County should adopt a clear definition of the I-82/US 730 Interchange function into their respective comprehensive plan and TSP as a policy to provide direction for management of the interchange area and achieve the objectives and goals of this IAMP. This will help to ensure consistency between future policy decisions with the interchange’s intended function.

The I-82/US 730 interchange provides connections between the I-82, US 730, and US 395 corridors. I-82 is a short, but significant interstate highway that connects the state of Washington to the I-84 corridor. I-82 is classified as an Interstate Highway by the Oregon Highway Plan (OHP) and designated as an Expressway and Statewide Freight Route. US 730 is a Regional Highway that provides regional connectivity between numerous local jurisdictions and the Interstate 82/I-84 interstate highways.

Based on this description, the following function and policy definition was developed for the I-82/US 730 Interchange:

“The primary transportation function of the I-82/US 730 interchange is to facilitate statewide, interurban, and inter-regional travel between I-82, US 730, and US 395. In

addition to this primary function, the I-82/US 730 interchange provides east-west inter-regional connectivity across I-82 for the City of Umatilla and surrounding land uses. Beyond these primary functions, the interchange provides an inter-regional connection that supports local, regional, and state business interests.”

12.3.812 IAMP Management Area

The City of Umatilla is the land use regulatory authority for most of the IMSA; for land that is located outside of the City’s UGB, Umatilla County is the land use regulatory authority. To ensure the continued operation and safety integrity of the interchange, both the City of Umatilla and Umatilla County should adopt an IAMP Management Area. Future development and land use actions within the IAMP Management Area will be monitored to ensure that volume-to-capacity ratios do not exceed the adopted Oregon Highway Plan mobility standards at the ramp terminals. This can be accomplished through Development Review guidelines included within the proposed amendments to the City’s Land Use and Development Ordinances as described in the following sections.

12.3.820 Adoption Elements

Implementation of the I-82/US 730 IAMP will occur at several levels of government. As required by OAR 734-051, the City of Umatilla and Umatilla County will be required to legislatively amend their Transportation System Plans and Comprehensive Plans to incorporate elements of the I-82/US 730 IAMP. In addition, new ordinances or amendments to existing ordinances, resolutions, and Inter-Governmental Agreements (IGAs) will be required to ensure that the access management, land use management, and coordination elements of the IAMP are achieved. This adoption process will include Planning Commission/City Council hearings at the city level and Planning Commission/County Board of Commissioners hearings at the County level. Following successful adoption at the City and County levels, the I-82/US 730 IAMP will be presented to the Oregon Transportation Commission (OTC) for its review and adoption. This should occur prior to transportation improvements as described in this IAMP being constructed.

To implement the I-82/US 730 IAMP, the following actions shall occur:

1. The City of Umatilla shall adopt the I-82/US 730 IAMP as part of the City of Umatilla Transportation System Plan and Comprehensive Plan. The IAMP, and more specifically the transportation improvements identified in Table 12.3-15 of Section 12.3.700, shall serve as the long range comprehensive management plan for providing the transportation facilities that are specifically addressed in this plan, as well as the Access Management Plan and the planned local street network for the area.
2. Umatilla County shall adopt the I-82/US 730 IAMP as part of the Umatilla County Transportation System Plan and Comprehensive Plan. The IAMP shall serve as the long range comprehensive management plan for providing the transportation facilities that are specifically addressed in this plan, as well as the Access Management Plan and the planned local street network for the area.

3. The City of Umatilla shall amend its Comprehensive Plan Map and Zoning Map to include the IAMP Management Area boundary. In addition, the City shall amend the Land Use and Development Ordinance to include development and land use application requirements pertaining to transportation impact analysis, access management, and agency coordination.
4. Umatilla County shall amend its Comprehensive Plan Map and Zoning Map to include the IAMP Management Area boundary. In addition, the County shall amend the Land Use and Development Ordinance to include development and land use application requirements pertaining to transportation impact analysis, access management, and agency coordination.
5. ODOT Regional Access Management Engineer will review and approve the access deviations described in the IAMP.
6. The Oregon Transportation Commission shall amend the Oregon Highway Plan to include the I-82/US 730 IAMP.
7. The City of Umatilla, Umatilla County, and ODOT shall develop a Memorandum of Understanding (MOU) that specifies how the improvements identified in Table 12.3-15 of Section 12.3.700 will be addressed.

12.3.821 TSP Amendments

The following outline discusses the major Transportation System Plan amendments that will need to occur at the city, county, and state levels to support adoption of the I-82/US 730 IAMP.

12.3.822 City of Umatilla

The City shall adopt the I-82/US 730 Interchange Area Management Plan as an element of the City's Transportation System Plan.

The following interchange policy statement shall be included in the City of Umatilla Transportation System Plan: *“The primary transportation function of the I-82/US 730 interchange is to facilitate statewide, inter-urban, and inter-regional travel between I-82, US 730, and US 395. In addition to this primary function, the I-82/US 730 interchange provides east-west inter-regional connectivity across I-82 for the City of Umatilla and surrounding land uses. Beyond these primary functions, the interchange provides an inter-regional connection that supports local, regional, and state business interests.”*

The IAMP Transportation Improvement Plan, as illustrated in *Figure 12.3-24* and listed in Table 12.3-15, shall be included in the recommended transportation improvements project list of the Transportation System Plan.

12.3.823 Umatilla County

The County shall adopt the I-82/US 730 Interchange Area Management Plan by reference as an element of the County's Transportation System Plan.

Upon the County's adoption of the IAMP, parcels within the IMSA and outside the UGB will be subject to the IAMP's Access Management Plan.

The following interchange policy statement should be included in the Umatilla County Transportation System Plan: *"The primary transportation function of the I-82/US 730 interchange is to facilitate statewide, inter-urban, and inter-regional travel between I-82, US 730, and US 395. In addition to this primary function, the I-82/US 730 interchange provides east-west inter-regional connectivity across I-82 for the City of Umatilla and surrounding land uses. Beyond these primary functions, the interchange provides an inter-regional connection that supports local, regional, and state business interests."*

The IAMP transportation improvement plan elements located on County facilities, as illustrated in *Figure 12.3-24* and listed in *Table 12.3-15*, shall be included in the recommended transportation improvements project list of the Umatilla County Transportation System Plan.

The IAMP Access Management Plan elements, as illustrated in *Figure 12.3-29*, shall be included in the transportation improvement project list of the Transportation System Plan.

12.3.824 Oregon Transportation Commission

The I-82/US 730 IAMP shall be adopted by the Oregon Transportation Commission as part of the Oregon Highway Plan.

12.3.825 Other City Amendments

The following outlines other major amendments that will need to occur at the city level to support adoption of the I-82/US 730 IAMP.

The City shall amend the Umatilla Code to establish a Gateway Sub-District under the General Commercial (GC) zone that addresses potential future redevelopment of the Port of Entry (POE) site. This sub-district will require specific development standards and specify restricted uses.

12.3.830 Monitoring Elements

The purpose of the IAMP is to ensure that capacity at the interchange is preserved for its intended function. While a long-range plan, the IAMP needs to remain dynamic and responsive to development and changes to the adopted land use and transportation plans and may need to be periodically reviewed and updated. To accomplish this goal, a monitoring program is included that identifies triggers for reviewing the IAMP and assessing how development approval within the IAMP Management Area will be reviewed and coordinated

12.3.831 IAMP Review Triggers

Periodically, the implementation program shall be evaluated by the City, ODOT, and County to ensure it is accomplishing the goals and objectives of the IAMP. Events that may trigger an IAMP review include:

- Plan map and zone changes within the IAMP Management Area that have a "significant affect" pursuant to the Transportation Planning Rule (TPR), Section -0060 and impact the

Interstate 82/US 730 Interchange, or proposed actions that meet the Traffic Impact Analysis conditions within the I-82/US 730 Interchange Overlay Zone.

- Designation of any proposed Multi-Modal Mixed Use Area (MMA) as defined in the TRP, Section -0060 that is located within the IAMP Management Area.
- Following relocation of the POE.
- The 95th-percentile westbound vehicle queue on US 730 exceeds two vehicles or backs into the I-82/US 730 Southbound ramp terminal.
- Mobility measures at the I-84 ramp terminals exceed the adopted volume-to-capacity ratios.

In addition to the established triggers for IAMP review, the agencies may request a review of the IAMP at any time if, in their determination, specific land use or transportation changes warrant a review of the underlying assumptions and/or recommendations within the IAMP. If the participants in the IAMP review meeting agree that, once the impacts of the “trigger” that necessitated the review are examined, an IAMP amendment is not warranted, a recommendation of “no action” may be documented and submitted in the form of a letter to the City of Umatilla City Council, Umatilla County Board of Commissioners, and the Oregon Transportation Commission.

If the findings and conclusions from the IAMP review meeting demonstrate the need for an update to the plan, review participants will initiate an IAMP update process. Initial steps in updating the IAMP will include scoping the planning process, identifying funding, and outlining a schedule for plan completion. Once completed, IAMP updates will be required to be legislatively adopted, requiring a City Council public hearing, as an amendment to the City of Umatilla Transportation System Plan and will be adopted by Umatilla County Board of Commissioners (if affected) and the Oregon Transportation Commission as an update to the Oregon Highway Plan

12.3.832 Development Review within the Overlay District

The following outlines the transportation requirements for development and zone change applications within the I-82/US 730 Interchange Overlay Zone and describes how the City of Umatilla and Umatilla County will coordinate with ODOT.

12.3.832(1) Traffic Impact Analysis

All development applications located within the I-82/US 730 Interchange Management Area that meet the following conditions are required to prepare and submit a Transportation Impact Analysis (TIA) to demonstrate the level of impact of the proposed development on the surrounding street system:

- A. A change in zoning or plan amendment designation; and

- B. The proposal is projected to cause one or more of the following effects, which can be determined by field counts, site observation, traffic impact analysis or study, field measurements, crash history, Institute of Transportation Engineers *Trip Generation* manual; and information and studies provided by the local reviewing jurisdiction and/or ODOT:
- i) An increase in site traffic volume generation by 250 average daily trips (ADT) or more (or as required by the City Engineer). The latest edition of the *Trip Generation* manual, published by the Institute of Transportation Engineers (ITE) shall be used as standards by which to gauge average daily vehicle trips; or
 - ii) An increase in use of adjacent streets by vehicles exceeding the 20,000 pound gross vehicle weights by 10 vehicles or more per day; or
 - iii) The location of the access driveway does not meet minimum intersection sight distance requirements, or is located where vehicles entering or leaving the property are restricted, or vehicles queue or hesitate, creating a safety hazard; or
 - iv) A change in internal traffic patterns that may cause safety problems, such as back up onto the highway or traffic crashes in the approach area; or.
 - v) For development in the I-82/US 730 Interchange Area Management Plan (IAMP) Management Area, the location of the access driveway is inconsistent with the Access Management Plan in Section 12.3.700 of the IAMP

The determination of impact or effect, and the scope of the TIA, shall be coordinated with the City of Umatilla, Umatilla County, and ODOT. The developer shall be required to mitigate impacts attributable to the project.

12.3.832(2) ODOT Coordination

The City shall consult the Oregon Department of Transportation (ODOT) on TIA requirements when the site of the proposal is adjacent to or otherwise affects a State roadway.

The City shall provide written notification to ODOT once the application is deemed complete.

ODOT shall have at least 20 days, measured from the date notice to agencies was mailed, to provide written comments to the City. If ODOT does not provide written comments during this 20-day period, the City staff report will be issued without consideration of ODOT comments.

The County shall invite ODOT to participate in a pre-filing conference for applications within an Interchange Management Area Plan (IAMP) Management Area or within a ¼ mile of any ODOT facility.

12.3.840 POE Relocation Related Actions

A major component of the I-82/US 730 IAMP centers on a potential future relocation of the POE. Given the uncertainty of the timing and the numerous logistical details that come with the relocation, it is expected that additional actions will need to be taken by the City of Umatilla, ODOT, and Umatilla County. For guidance purposes, the Implementation section of the IAMP has identified these likely next steps.

12.3.841 Surplus Process

When funding becomes available and the POE is relocated, the State of Oregon will be in a position to potentially sell the existing POE site for future redevelopment. In order for this to occur, the State will first have to declare the POE site as surplus property. It is recognized that declaring the POE site as surplus property is an important first step to ensuring redevelopment of the site and some of the associated infrastructure projects envisioned in the IAMP. The most significant infrastructure change involves the realignment of Brownell Boulevard. To ensure that the realignment takes place as envisioned, ODOT will follow the policies and procedures established in Chapter 9 of ODOT's Right-of-Way Manual.

12.3.842 Brownell Realignment

Because the necessary steps for a long-term Brownell realignment involve ODOT (owner of the POE site), City (governing jurisdiction), and Umatilla County (owner of the existing Brownell Boulevard), it is anticipated that all three jurisdictions will need address the following issues when the POE site is formally relocated and redevelopment of the POE site take place.

- Timing of jurisdictional transfer of the realigned Brownell Boulevard to the City. This jurisdictional transfer is outlined in Chapter 9 of ODOT's Right-of-Way Manual.
- The City will establish a funding mechanism that will ensure construction of the Brownell Boulevard re-alignment as part of the future redevelopment of the POE.
- Land Use Permitting for the POE site.

12.3.850 Disclaimer

The inclusion of proposed projects and actions in this plan does not obligate or imply obligations of funds by any jurisdiction for project level planning or construction. The inclusion of proposed projects and actions does serve as an opportunity for the projects to be included, if appropriate, in the State Transportation Improvement Program (STIP) and the local Capital Improvement Program (CIP), but such inclusion is not automatic. It is incumbent on the state, county, city, and general public to take action to encourage and support inclusion in the STIP or CIP at the appropriate time. Because a project must have actual identified funding to be included in the STIP or CIP, the ultimate number of projects that can be included in these documents is constrained by available funding. The state transportation system improvement projects that are expected to be funded by ODOT that are listed on the transportation improvement project list have no guaranteed funding at this time and are not reasonably likely to be funded during the identified planning horizon for the purpose of addressing OAR 660-0012-0060.

12.3.900 OAR AND OHP COMPLIANCE

The following section discusses the Oregon Administrative Rule (OAR) and 1999 Oregon Highway Plan (OHP) policy based compliance issues that pertain to the development of the I-82/US 730 IAMP.

12.3.910 OAR Compliance

The I-82/US 730 IAMP was developed in collaboration with the City of Umatilla, Umatilla County, and ODOT and was developed in accordance with the guidelines set forth in the State of Oregon’s Oregon Administrative Rules for Interchange Access Management Planning and Interchange Area Management Planning. Table 12.3-16 identifies the required planning elements from OAR 734-051 and documents how the I-82/US 730 IAMP satisfies the requirements.

Table 12.3-16 OAR 734-051 Issues Addressed

OAR 734-0051-0155 Requirement	How Addressed	Report Reference
Should be developed no later than the time the interchange is being developed or redeveloped -0155(7)(a)	This plan was developed in order to determine the future improvements that would enhance the efficiency and safety of the interchange. The plan was completed before any of the identified improvements to the interchange moved into project development phases.	Section 12.3.100
Should identify opportunities to improve operations and safety in conjunction with roadway projects and property development or redevelopment and adopt strategies and development standards to capture those opportunities - 0155(7)(b)	The access management, transportation improvement plan, and overlay district elements identified in this plan will result in operational and capacity improvements.	Section 12.3.700 Section 12.3.800
Should include short, medium, and long-term actions to improve operations and safety in the interchange area -0155(7)(c)	The IAMP includes a phasing plan for the transportation system improvements and access management elements that cover the short, medium, and long-term time timeframes.	Section 12.3.700 Section 12.3.800
Should consider current and future traffic volumes and flows, roadway geometry, traffic control devices, current and planned land uses and zoning, and the location of all current and planned approaches -0155(7)(d)	A full analysis of existing and forecast (2030) operational and geometric conditions was conducted for this planning effort. The future volumes were developed based on current zoning and comprehensive plan designations. All approaches, existing and planned, were examined.	Section 12.3.400 Section 12.3.500 Section 12.3.600
Should provide adequate assurance of the safe operation of the facility through the design traffic forecast period, typically 20 years -0155(7)(e)	The forecast analysis shows that safe operations will be achieved for the interchange through 2030.	Section 12.3.600
Should consider existing and proposed uses of all property in the interchange area consistent with its comprehensive plan designations and zoning -155(7)(f)	A thorough analysis of surrounding land uses and land use potential was performed based on the current comprehensive plan designations and zoning.	Section 12.3.400 Section 12.3.500 Section 12.3.600 Section 12.3.700

OAR 734-0051-0155 Requirement	How Addressed	Report Reference
Is consistent with any applicable Access Management Plan, corridor plan or other facility plan adopted by the Oregon Transportation Commission 0155(7)(g)	The I-82/US 730 Interchange Area Management Plan is consistent with the 1999 OHP. (See following subsection). No other applicable plans adopted by the OTC were identified.	Section 12.3.300 Section 12.3.800
Includes polices, provisions and standards from local comprehensive plans, transportation system plans, and land use and subdivision codes that are relied upon for consistency and that are relied upon to implement the Interchange Area Management Plan. -155(7)(h)	Implementation of the IAMP is reliant upon the City of Umatilla and Umatilla County amending their respective Transportation System Plans to incorporate the transportation improvements associated with the IAMP. In addition, implementation of the IAMP will occur through the City of Umatilla and Umatilla County amending their Land Use and Development Ordinances to include an IAMP overlay district. The overlay district contains the submittal requirements and review standards for land use amendment and development proposals within the district; access management standards and local street connectivity requirements will be based on the IAMP. Amendments will ensure that future development and land use actions within the interchange management area do not degrade the interchange terminal volume to capacity ratios below the adopted OHP mobility standards. These amendments include coordination between agencies, traffic impact analysis requirements, monitoring of traffic operations, and access management requirements.	Section 12.3.300 Section 12.3.700 Section 12.3.800

THE PLAN WILL DETERMINE		
OAR 734-051-0155 Requirement	Determination	Report Reference
Driveway and roadway spacing and connections	The operational analysis considered all access points and intersections within approximately ½ mile from the existing I82/US 730 Interchange, including all key intersections that have potential to affect traffic operations in the interchange area over the planning period. The resulting Access Management element moves toward the ¼ mile spacing requirement.	Section 12.3.700
Local street connections to ensure adequate access to properties and off-highway circulation	The IAMP maintains much of the existing local circulation network and includes improvements to it (Figure 12.3-24).	Section 12.3.700
Median treatments	Median treatments are proposed for US 730 to meet ODOT access management standards (Figure 12.3-29).	Section 12.3.700
Location and type of traffic control devices needed to ensure safe and efficient operations in the operational area of the interchange	The I-82 Northbound ramp terminal will be signalized as part of the short-term improvements. Figure 12.3-24 shows all necessary traffic control within the IMSA.	Section 12.3.700
Location of sidewalks and bicycle lanes	Sidewalks and bicycle lanes will be constructed with roadway improvements. Figure 12.3-24 shows the locations of future sidewalks and bicycle lanes.	Section 12.3.600 Section 12.3.700
Sidewalk and bicycle lane crossings (highway and ramp crossings)	See above.	See above
Location of potential transit facilities (turnouts, shelters, park and ride areas)	Transit facilities were not considered as part of the IAMP because fixed route transit service does not exist nor is planned within the IMSA.	NA

THE PLAN WILL DETERMINE		
OAR 734-051-0155 Requirement	Determination	Report Reference
Is new policy language needed in the City of Umatilla and Umatilla County Comprehensive Plans to support adequate long-term interchange operations?	The City of Umatilla and Umatilla County will amend their respective comprehensive plans to include the overlay district. In addition, the City and County will amend its land use and development ordinance to implement the overlay district.	Section 12.3.800
Are any land use changes/ comprehensive plan (including TSP) amendments needed to implement the Interchange Area Management Plan?	The City of Umatilla and Umatilla County will amend their respective Transportation System Plans to incorporate the transportation improvements associated with the IAMP. The City of Umatilla and Umatilla County will amend their respective Land Use and Development Ordinances to include an Interchange Area Management Plan Overlay District that contains the submittal requirements and review standards for land use amendment and development proposals within the district. Amendments will ensure that future development and land use actions within the interchange management area do not degrade the interchange terminal volume to capacity ratios below the adopted OHP mobility standards. These amendments include coordination between agencies, traffic impact analysis requirements, monitoring of traffic operations, and access management requirements.	Section 12.3.800
Are any deviations from OHP and OAR 731-051 standards and requirements needed?	Deviations to the OHP access spacing standards are required, as described under Section 12.3.700 and subsections. The Access Management element describes how each of the necessary deviations meets the requirements of Division 51. The IAMP and Implementation Plan define all the necessary standards and requirements.	Section 12.3.700 Section 12.3.800

12.3.920 Oregon Highway Plan Compliance

The I-82/US 730 IAMP was developed in accordance with the policies set forth in the Oregon Highway Plan (OHP). The following identifies the OHP policies that pertain to the I-82/US 730 IAMP and how the IAMP satisfies the requirements.

Policy 1A: State Highway Classification System. The state highway classification system includes five classifications: Interstate, Statewide, Regional, District, and Local Interest Roads. In addition, there are four special purpose categories that overlay the basic classifications: special land use areas, statewide freight route, scenic byways, and lifeline routes.

Within the IMSA, there are three ODOT highways. Interstate-82 is an Interstate Highway and is part of the National Highway System (NHS). US 730 is a Statewide Highway from the southbound I-82 ramp terminal east to US 395 and a Regional Highway west of the southbound terminal. US 395 is a Statewide Highway.

How Addressed: The I-82/US 730 IAMP recognized the respective functions of each highway. Relocating the POE will allow US 730 to serve its regional role, instead of all truck traffic. The

plan also includes accessory weigh facilities along US 730 and US 395, recognizing their need to serve freight traffic.

Policy 1B: Land Use and Transportation. This policy recognizes the role of both the State and local governments related to the state highway system and calls for a coordinated approach to land use and transportation planning.

How Addressed: The IAMP was developed through a cooperative planning effort between the City of Umatilla, Umatilla County, ODOT, and DLCD. The IAMP will be implemented by the City of Umatilla through an Interchange Management Overlay District that will require coordinated agency review on all future development or land use actions within the District.

Policy 1C: State Highway Freight System. This policy recognizes the need for the efficient movement of freight through the state. Interstate-82, US 395, and sections of US 730 are designated freight routes.

How Addressed: The transportation improvement plan improves traffic operations and safety along US 730 and at the interchange, which will ensure that freight mobility is preserved along the US 730 and US 395 corridors. The relocated POE along I-82 will also be able to more efficiently serve freight traffic than it is able to at its current location.

Policy 1F: Highway Mobility Standards Access Management Policy. This policy addresses state highway performance expectations, providing guidance for managing access and traffic control systems related to interchanges.

How Addressed: The I-82/US 730 IAMP demonstrates that the interchange will be able to meet ODOT mobility standards through the 20-year horizon. It also provides an access management element that improves access management within the IMSA.

Policy 1G: Major Improvements. This policy requires maintaining performance and improving safety by improving efficiency and management before adding capacity.

How Addressed: The I-82/US 730 IAMP provides measures to increase efficiency through access management and provides improvements to the local street system.

Policy 2B: Off-System Improvements. This policy recognizes that the state may provide financial assistance to local jurisdictions to make improvements to local transportation systems if the improvements would provide a cost-effective means of improving the operations of the state highway system.

How Addressed: Section 12.3.800 identifies a series of procedural steps that the City, County, and ODOT will take regarding improvements to the local circulation network, including the realignment of Brownell Boulevard. Specific access management responsibilities have been set according to State and City responsibilities.

Policy 2F: Traffic Safety. This policy emphasizes the state’s efforts to improve safety of all uses of the highway system. Action 2F.4 addresses the development and implementation of the Safety Management System to target resources to sites with the most significant safety issues.

How Addressed: The potential safety issues identified within the IMSA relate to queues spilling back from other intersections into the ramp terminals. The transportation improvement plan outlined in Section 12.3.700 addresses these issues. The access management element was also developed to ensure the long-term safety of the interchange area.

Policy 3A: Classification and Spacing Standards. This policy addresses the location, spacing and type of road and street intersections and approach roads on state highways. The adopted standards can be found in Appendix C of the Oregon Highway Plan.

How Addressed: See Policy 3C below.

Policy 3C: Interchange Access Management Areas. This policy addresses management of grade-separated interchange areas to ensure safe and efficient operation between connecting roadways. Action items include developing interchange area management plans to protect the function of the interchange to provide safe and efficient operations between connecting roadways and to minimize the need for major improvements of existing interchanges. The local jurisdiction’s role in access management is stated in Policy 3C as follows: “necessary supporting improvements, such as road networks, channelization, medians and access control in the interchange management area must be identified in the local comprehensive plan and committed with an identified funding source, or must be in place (Action 3C.2).”

Access management standards are detailed in Policy 3C and include the distance required between an interchange and approaches and intersections. The most stringent standards apply in interchange areas. Table 17 of the OHP contains the minimum spacing standards applicable to the I-82/US 730 Interchange, a freeway interchange that has a multi-lane crossroad. The spacing standards in an urban area for this type of interchange are:

- 1 miles (3.2 km) Distance between the start and end of tapers of adjacent interchanges.
- 750 feet (230 m) Distance to the first approach on the right (right in/right out only)
- 1,320 feet (400 m) Distance to the first major intersection or approach (left turns allowed).
- 990 feet (300 m) Distance between the last right in/right out approach road and the start of the taper for the on-ramp.

How Addressed: The I-82/US 730 IAMP includes an access management element that consolidates access points and improves access spacing over the existing conditions. Ultimately, upon land redevelopment, access on either side will be improved but it will not meet the standards outlined above. Section 12.3.700 outlines where deviations will be necessary and describes how each of the necessary deviations meets the requirements of Division 51.

Policy 4A: Efficiency of Freight Movement. This policy emphasizes the need to maintain and improve the efficiency of freight movement on the state highway system. Interstate-82, US 395, and sections of US 730 are designated Freight Routes.

How Addressed: The transportation improvement plan improves traffic operations and safety along US 730 and at the interchange, which will ensure that freight mobility is preserved along the US 730 and US 395 corridors. The relocated POE along I-82 will also be able to more efficiently serve freight traffic than it is able to at its current location.

Policy 5B: Scenic Resources. This policy applies to all state highways and commits the State to using best management practices to protect and enhance scenic resources in all phases of highway project planning, development, construction, and maintenance.

How Addressed: This policy was considered as part of the plan development.

12.3.950 INTERCHANGE AREA MANAGEMENT PLAN FINDINGS (RESERVED FOR EXPANSION)

12.3.970 INTERCHANGE AREA MANAGEMENT PLAN POLICIES (RESERVED FOR EXPANSION)

12.3.999 REFERENCES

1. Oregon Department of Transportation. *1999 Oregon Highway Plan*. 1999
2. City of Umatilla. *City of Umatilla Transportation System Plan*. 1999.
3. Oregon Department of Transportation. *Analysis Procedures Manual*. 2006.
4. Transportation Research Board. *Highway Capacity Manual*. 2000.
5. Institute of Transportation Engineers. *Trip Generation (8th Edition)*. 2008.
6. Oregon Department of Transportation. *Highway Design Manual*. 2003.