



READY-BUILD PLAN PROGRAM

PRESCRIPTIVE DECK

2017 ORSC

EFFECTIVE
MARCH, 2018

REVISIONS	
NO.	DATE

General Notes

S01

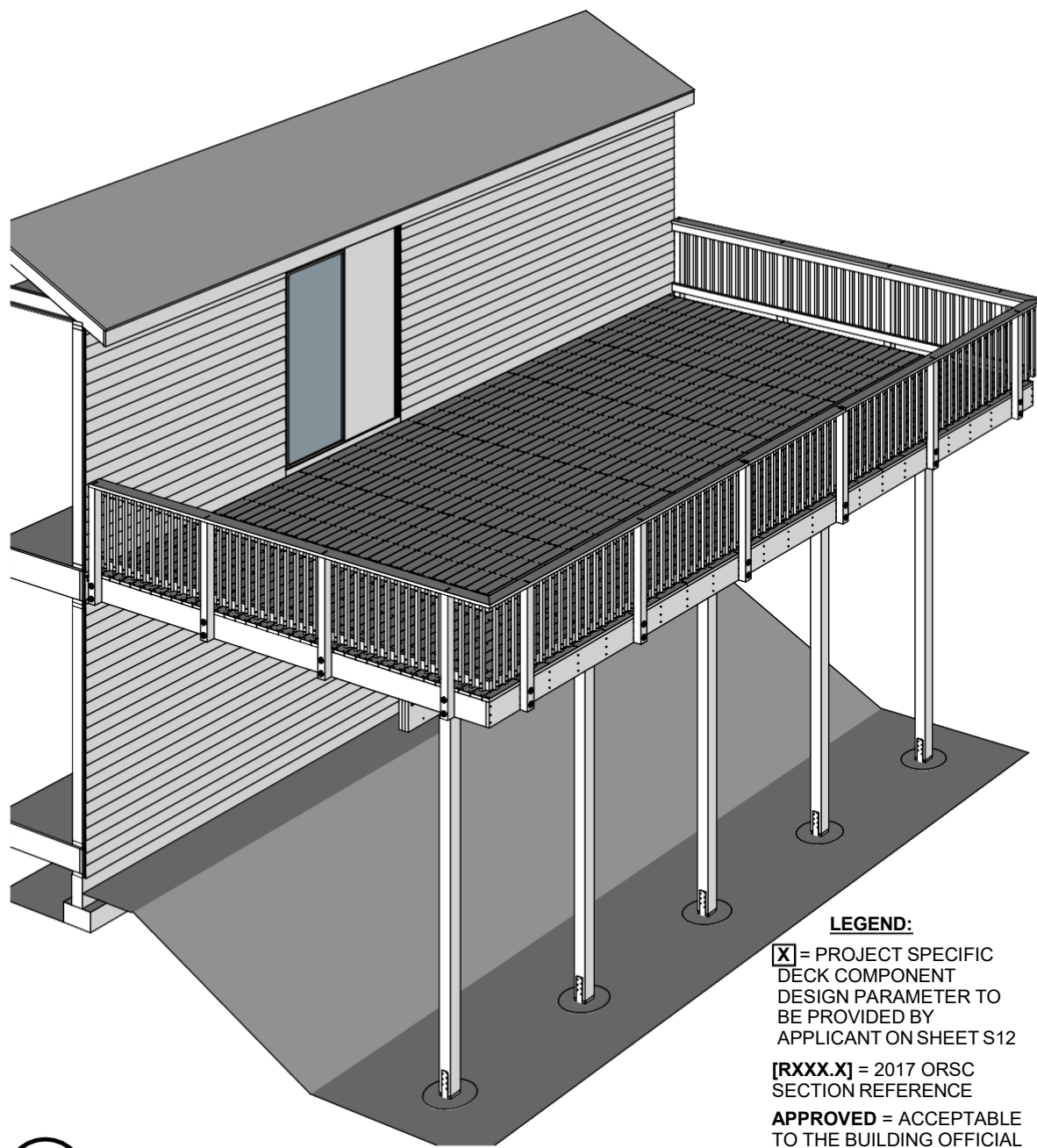

GENERAL NOTES

SCOPE

SINGLE LEVEL EXTERIOR DECKS ATTACHED TO THE EXTERIOR WALL OF A ONE- OR TWO-FAMILY DWELLING.

APPLICABLE BUILDING CODE

2017 OREGON RESIDENTIAL SPECIALTY CODE (ORSC).

LIMITATIONS OF USE

USE OF AND ANY MODIFICATIONS TO THESE READY-BUILD PLANS IS SUBJECT TO REVIEW AND APPROVAL BY THE BUILDING DEPARTMENT HAVING JURISDICTION.

- A. ULTIMATE WIND SPEED: 105-135MPH
- B. WIND EXPOSURE CATEGORY: B, C, OR D
- C. SEISMIC DESIGN CATEGORY: C, D₁, OR D₂
- D. GROUND SNOW LOAD: < 40 PSF

DECKS SUPPORTING LARGE CONCENTRATED LOADS SUCH AS HOT TUBS ARE BEYOND THE SCOPE OF THIS DOCUMENT.

APPLICANT SHALL USE THE CODE PRESCRIBED TABLES CONTAINED HEREIN AND RECORD THEIR PROJECT SPECIFIC DESIGN PARAMETERS (X) ON SHEET **S12** PRIOR TO PERMIT APPLICATION.

FOUNDATION

FOOTINGS SHALL BEAR ON NATIVE, INORGANIC, UNDISTURBED SOIL BELOW EXISTING GRADE. CONCRETE STRENGTH SHALL BE 3,000 PSI IN MODERATE WEATHERING REGIONS AND 3,500 PSI IN SEVERE WEATHERING REGIONS (SEE DETAIL 1/S11) [R301.2 AND R402.2].

WOOD FRAMING

ALL WOOD SHALL BE APPROVED NATURALLY DURABLE OR PRESSURE-PRESERVATIVE-TREATED (R317.1). ALL WOOD IN CONTACT WITH THE GROUND, OR EMBEDDED IN CONCRETE SHALL BE APPROVED PRESSURE-PRESERVATIVE-TREATED WOOD SUITABLE FOR GROUND CONTACT USE (R317.1.2). ALL CUTS SHALL BE FIELD TREATED WITH COPPER NAPHTHENATE (2% COPPER) [R402.1.2].

FASTENERS, ANCHORS, AND CONNECTORS FASTNERS SHALL BE HOT-DIPPED GALVANIZED, STAINLESS STEEL, OR APPROVED FOR USE WITH PRESERVATIVE-TREATED LUMBER. COATING TYPES FOR FRAMING ANCHORS SHALL BE IN ACCORDANCE WITH MFR'S RECOMMENDATIONS (SHALL BE PROVIDED WITH SUBMITTAL) [R317.3].

LEGEND:

(X) = PROJECT SPECIFIC DECK COMPONENT DESIGN PARAMETER TO BE PROVIDED BY APPLICANT ON SHEET S12

[RXXX.X] = 2017 ORSC SECTION REFERENCE

APPROVED = ACCEPTABLE TO THE BUILDING OFFICIAL [R202]

1 General Notes
S01 NTS



541-922-3226 (main)
City of Umatilla

READY-BUILD PLAN PROGRAM

PRESCRIPTIVE DECK

2017 ORSC

EFFECTIVE
MARCH, 2018

REVISIONS
NO. DATE

NO.	DATE

Elevation

S02

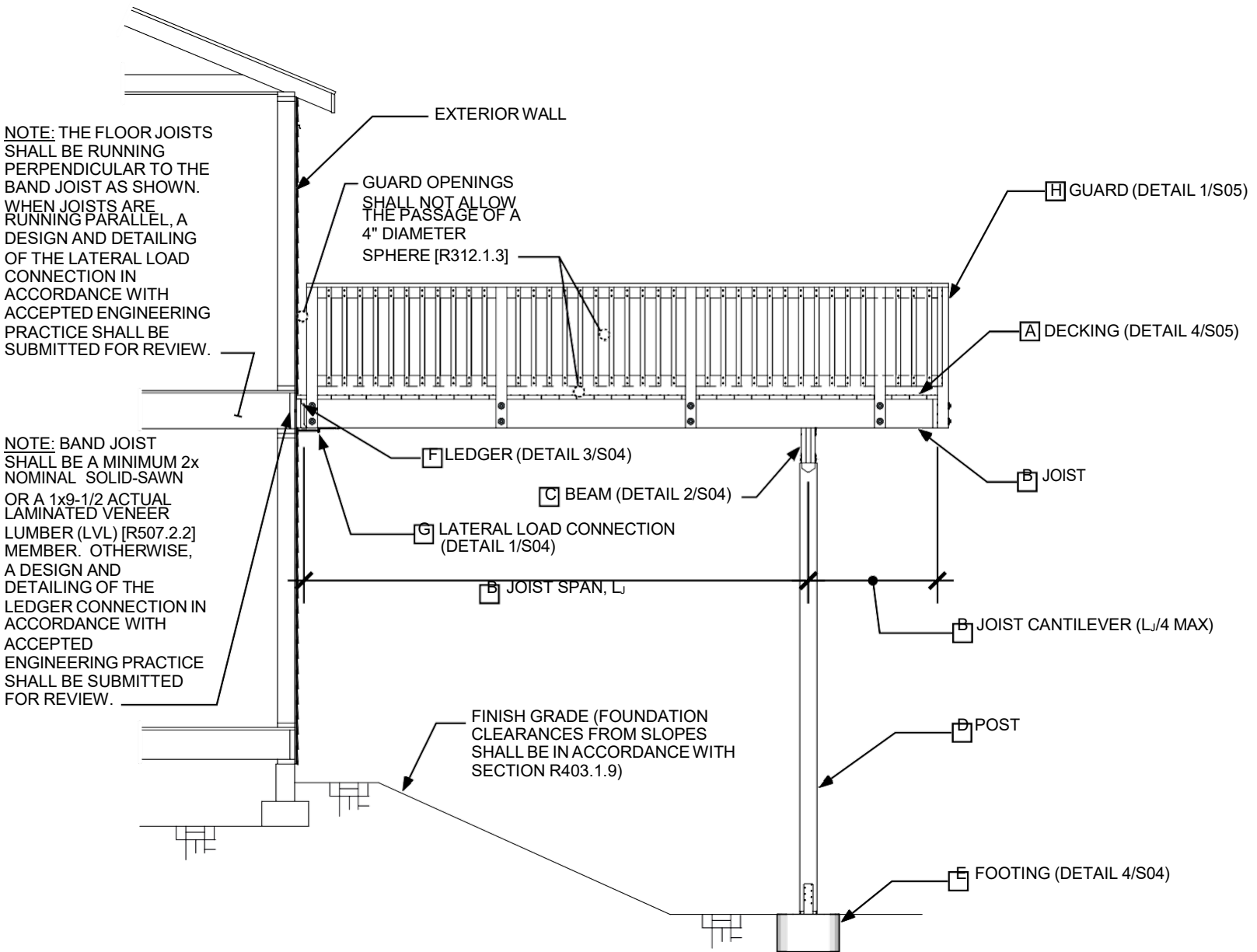

NOTE: THE FLOOR JOISTS SHALL BE RUNNING PERPENDICULAR TO THE BAND JOIST AS SHOWN. WHEN JOISTS ARE RUNNING PARALLEL, A DESIGN AND DETAILING OF THE LATERAL LOAD CONNECTION IN ACCORDANCE WITH ACCEPTED ENGINEERING PRACTICE SHALL BE SUBMITTED FOR REVIEW.

NOTE: BAND JOIST SHALL BE A MINIMUM 2x NOMINAL SOLID-SAWN OR A 1x9-1/2 ACTUAL LAMINATED VENEER LUMBER (LVL) [R507.2.2] MEMBER. OTHERWISE, A DESIGN AND DETAILING OF THE LEDGER CONNECTION IN ACCORDANCE WITH ACCEPTED ENGINEERING PRACTICE SHALL BE SUBMITTED FOR REVIEW.

1 Side Elevation
S02 NTS



READY-BUILD PLAN PROGRAM

PRESCRIPTIVE DECK

2017 ORSC

EFFECTIVE
MARCH, 2018

REVISIONS NO.	DATE

Perspective

S03

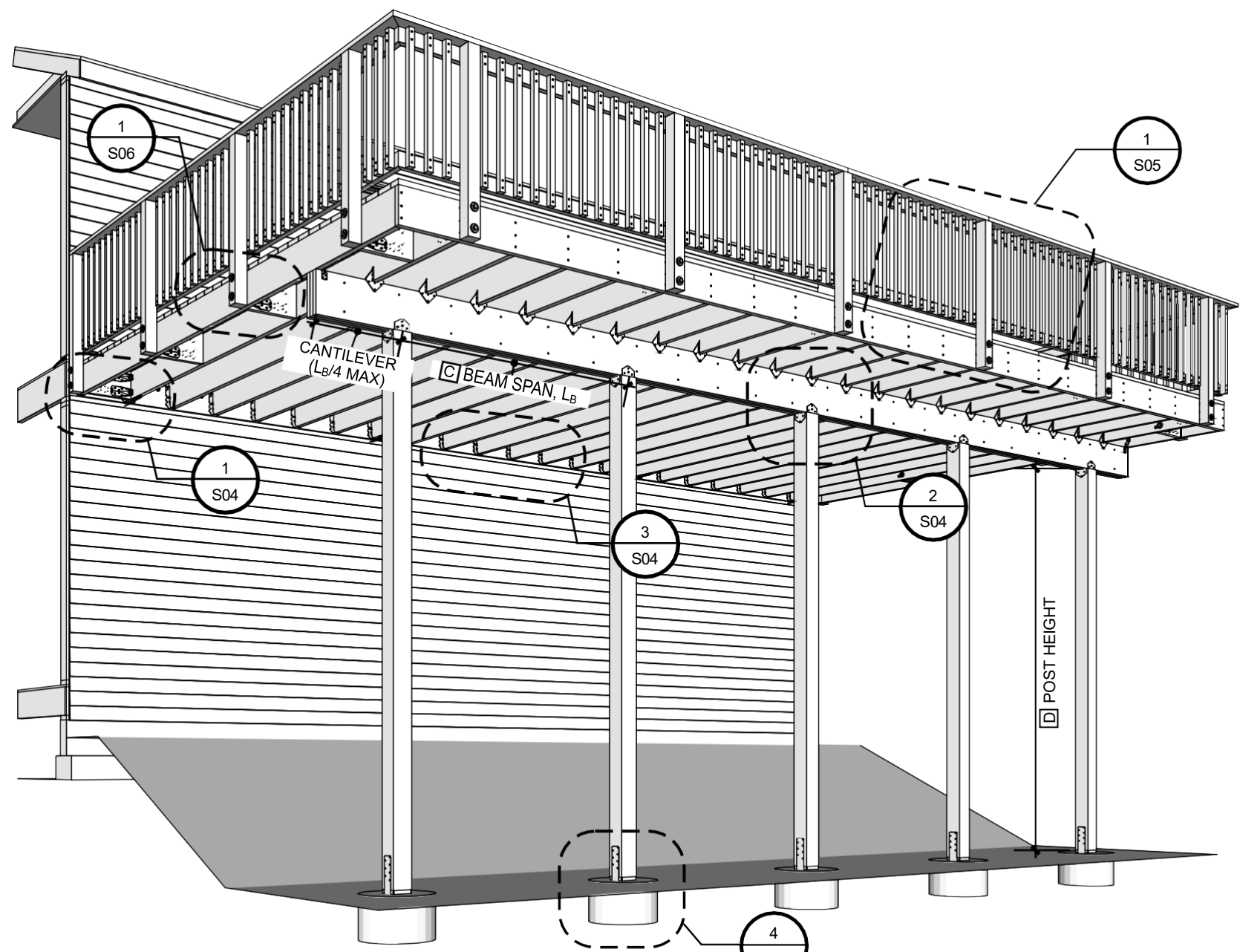

1 Deck Perspective
S03 NTS



READY-BUILD PLAN PROGRAM

PRESCRIPTIVE DECK

2017 ORSC

EFFECTIVE
MARCH, 2018

REVISIONS	
NO.	DATE

Details

S04

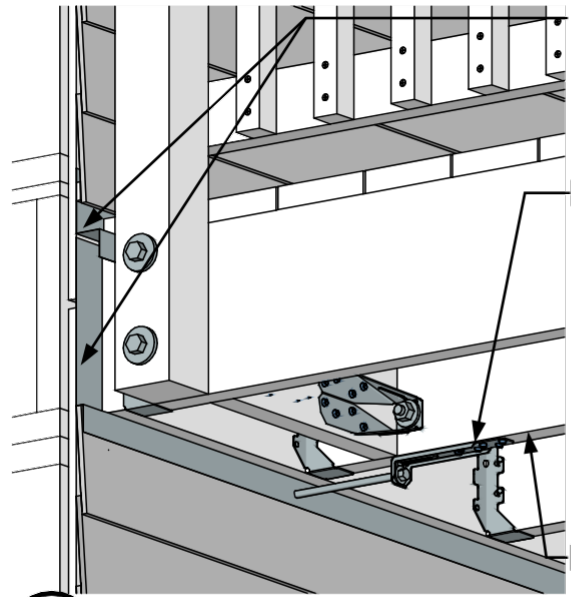

CORROSION-RESISTANT FLASHING INSTALLED IN SHINGLE-FASHION FOR WATER TIGHTNESS WHERE DECK MEETS EXTERIOR WALL [R703.4]

G HOLD-DOWN DEVICE WITH MIN 750 LB. CAPACITY AT 4 LOCATIONS, EVENLY DISTRIBUTED ALONG DECK AND ONE WITHIN 24" OF EACH END OF THE LEDGER. DEVICE SHALL BE INSTALLED IN ACCORDANCE WITH MANUFACTURER'S RECOMMENDATIONS [R507.2.4]. SEE DETAIL 2/S06 FOR ALTERNATE CONNECTION

B DECK JOIST PER DETAIL 2/S07

1 Lateral load connection
S04 NTS

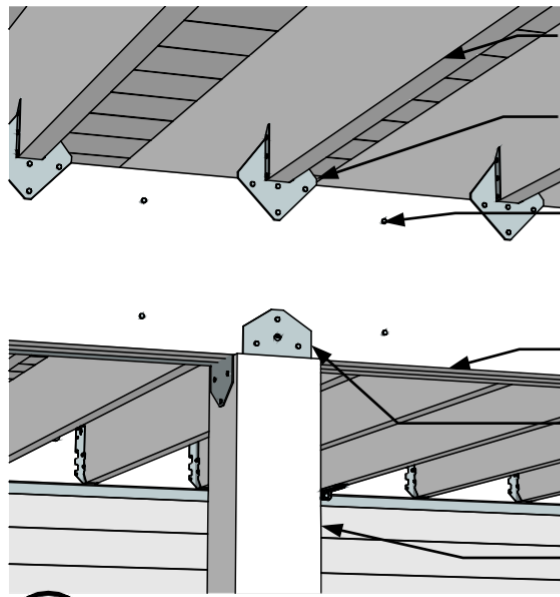

B DECK JOIST PER DETAIL 1/S07, TYP

APPROVED JOIST TO BEAM CONNECTOR [R507.7]

BEAM PLYS SHALL BE FASTENED WITH (2) ROWS OF 10D NAILS MIN AT 16" O.C. ALONG EACH EDGE [R507.6]

C DECK BEAM PER DETAIL 1/S09

APPROVED BEAM TO POST CONNECTOR [R507.7.1]. SEE DETAIL 3/S06 FOR ALTERNATE CONNECTION

D DECK POST PER DETAIL 2/S09

2 Joist to beam and beam to post connection
S04 NTS

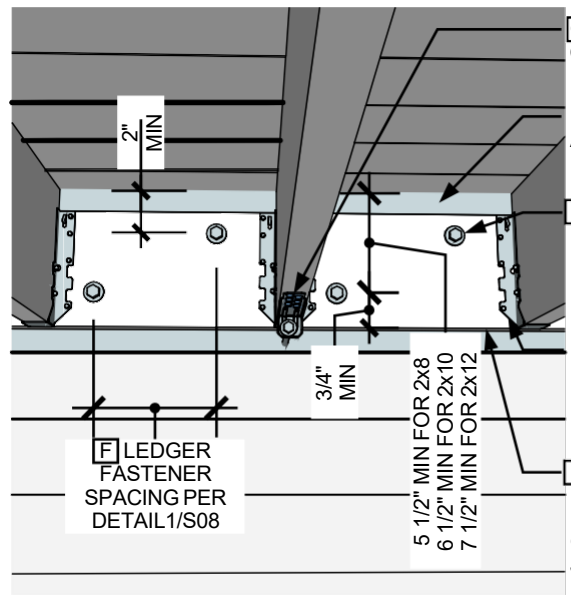

G LATERAL LOAD CONNECTION PER DETAIL 1/S04 OR 2/S06

FLASHING BETWEEN DECK AND EXTERIOR WALL PER DETAIL 1/S04

F DECK LEDGER FASTENING PER DETAILS 1/S08 AND 2/S08, STAGGERED AS SHOWN

APPROVED JOIST HANGER WITH DEPTH NOT LESS THAN 60% OF JOIST DEPTH [R507.7 AND R507.5.1]

F DECK LEDGER (2x8 MINIMUM) PER DETAIL 1/S12 EQUAL TO OR GREATER THAN THE DECK JOIST DEPTH

3 Ledger connection
S04 NTS

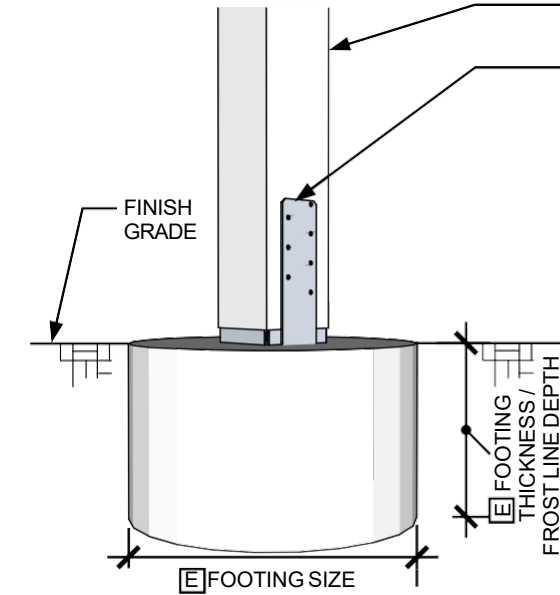

D DECK POST PER DETAIL 2/S09

APPROVED POST TO FOOTING CONNECTOR INSTALLED IN ACCORDANCE WITH MFR'S INSTRUCTIONS [R507.8.1]

E FOOTING SIZE PER 1/S10

E FOOTING THICKNESS / FROSTLINE DEPTH

NOTE: SEE DETAIL 4/S06 FOR ALTERNATE POST TO FOOTING CONNECTIONS

4 Post to footing connection
S04 NTS

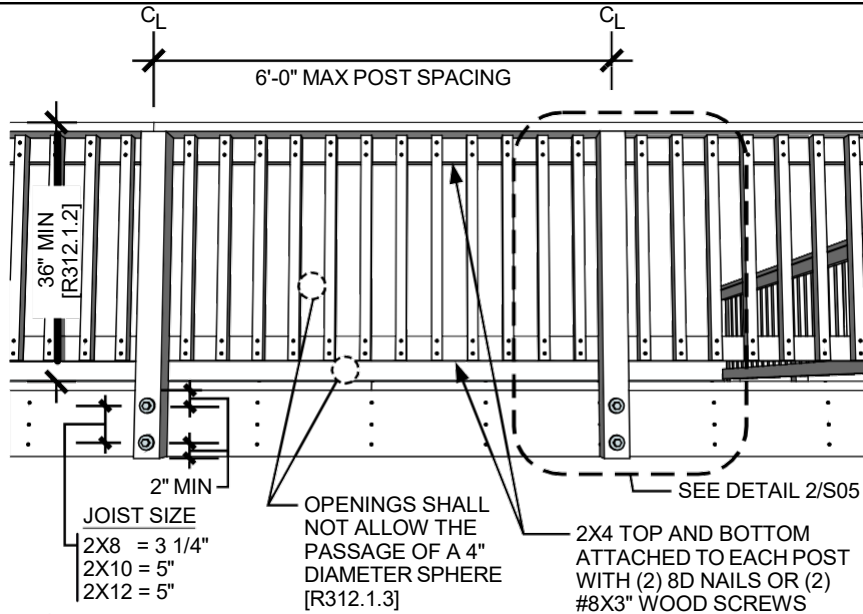

1 Deck guard
S05 NTS

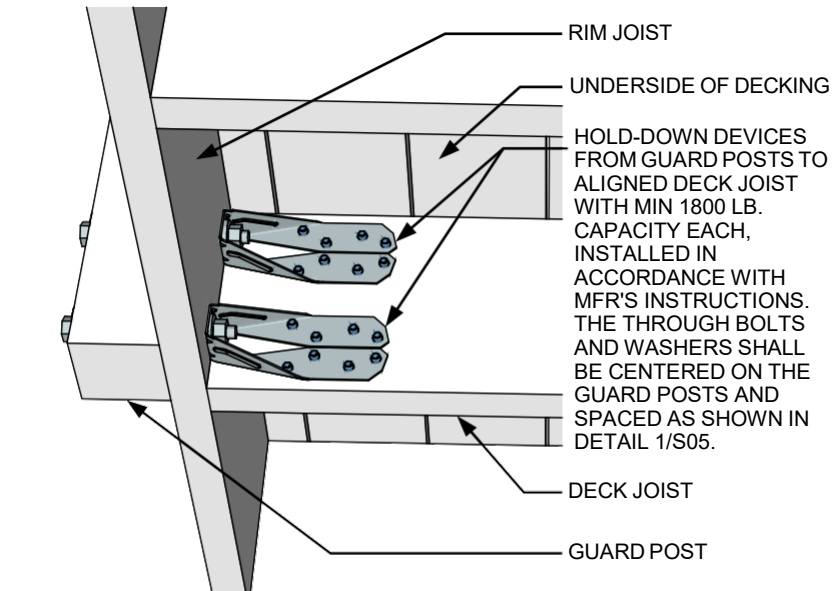

3 Guard post to joist connection
S05 NTS

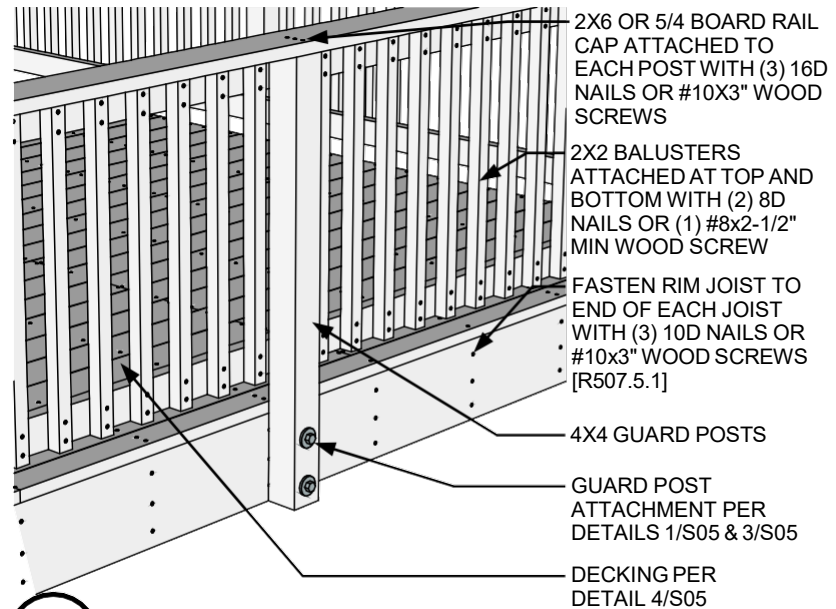

2 Deck guard
S05 NTS

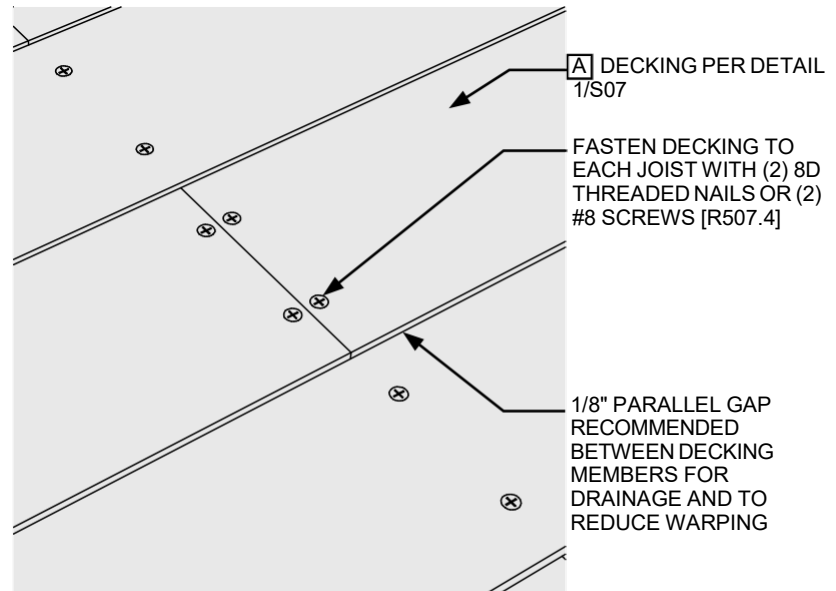

4 Decking connection
S05 NTS



READY-BUILD PLAN PROGRAM

PRESCRIPTIVE DECK

2017 ORSC

EFFECTIVE
MARCH, 2018

REVISIONS
NO. DATE

NO.	DATE

Details

S05



READY-BUILD PLAN PROGRAM

PRESCRIPTIVE DECK

2017 ORSC

EFFECTIVE
MARCH, 2018

REVISIONS NO.	DATE

Details

S06

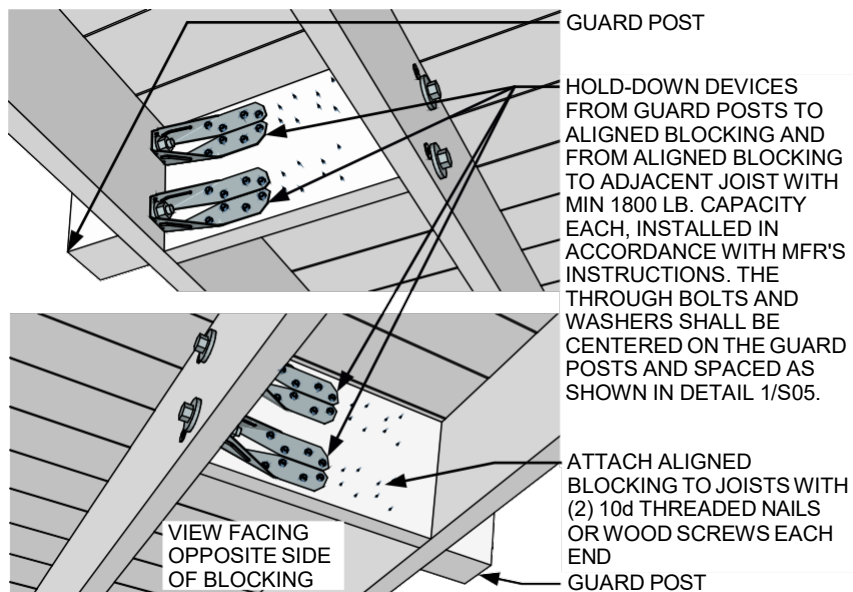

1 Guard post to blocking connection
S06 NTS

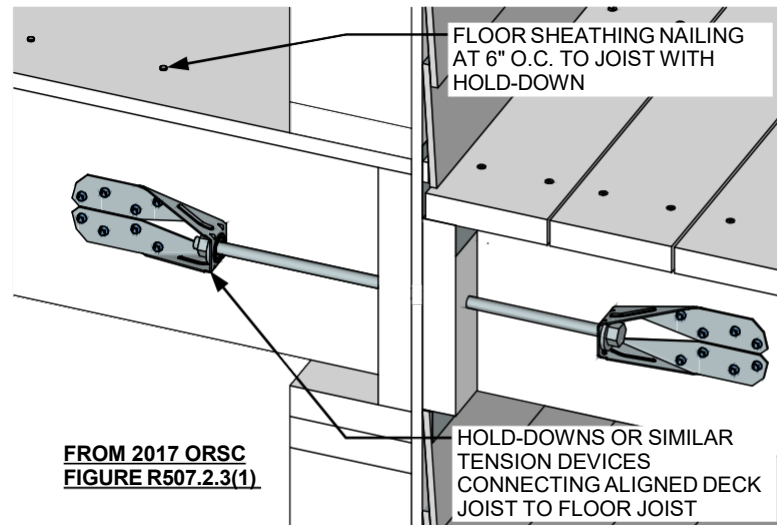

FROM 2017 ORSC
FIGURE R507.2.3(1)

NOTE: HOLD-DOWN TENSION DEVICES PER THIS DETAIL SHALL HAVE 1,500 LB. MINIMUM CAPACITY, BE INSTALLED IN NOT LESS THAN TWO LOCATIONS, AND BE WITHIN 24 INCHES OF EACH END OF DECK.

2 Alternate deck attachment for lateral loads
S06 NTS

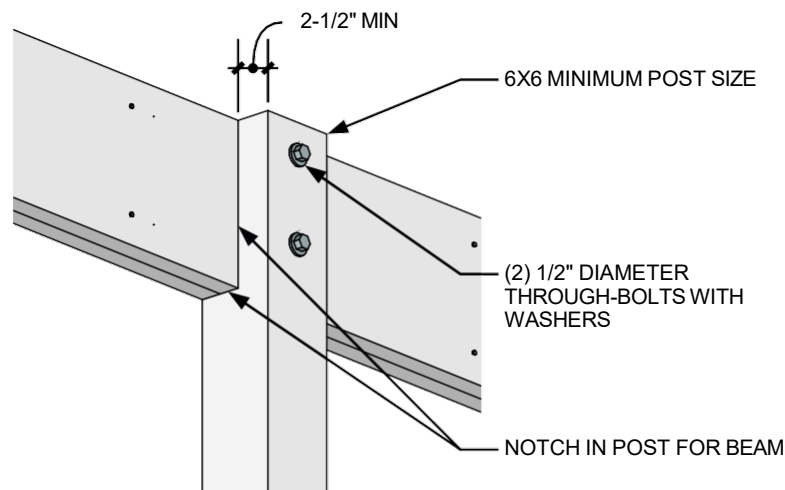

FROM 2017 ORSC FIGURE R507.7.1

NOTE: ALL BOLTS SHALL HAVE WASHERS UNDER THE HEAD AND NUT.

3 Alternate beam to post connection
S06 NTS

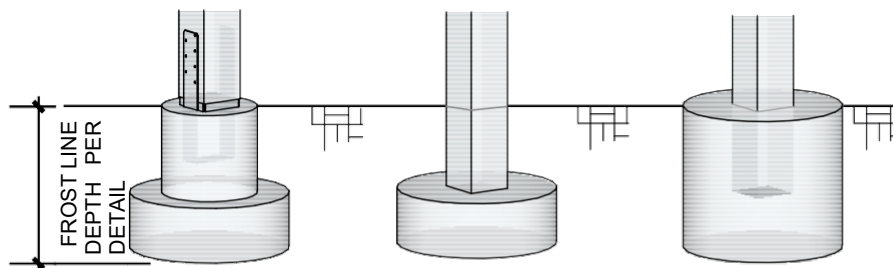

FROM 2017 ORSC FIGURE R507.8.1

NOTE: POSTS SHALL BE RESTRAINED TO PREVENT LATERAL DISPLACEMENT AT THE BOTTOM OF SUPPORT. SUCH RESTRAINT SHALL BE PROVIDED BY MANUFACTURED CONNECTORS INSTALLED IN ACCORDANCE WITH THE MANUFACTURER'S INSTRUCTIONS OR A MINIMUM POST EMBEDMENT OF 12 INCHES IN SURROUNDING SOILS OR CONCRETE.

4 Alternate post to footing connections
S06 NTS

**FROM 2017 ORSC TABLE R507.4
JOIST SPACING**

DECKING TYPE AND NOMINAL SIZE	MAXIMUM ON-CENTER JOIST SPACING (in.)	
	Perpendicular to joist	Diagonal to joist ^a
5/4-inch-thick wood	16	12
2-inch-thick wood	24	16
Plastic composite ^b	Per decking manufacturer	Per decking manufacturer

- a. Maximum angle of 45 degrees from perpendicular for wood deck boards.
b. Plastic composite deck materials shall comply with the requirements of ASTM D7032 and Section R507.3.

1
S07 Maximum Joist Spacing Table (from 2017 ORSC Table R507.4)
NTS

JOIST SPANS, L_J (ft.-in.)

SPECIES ^a	SIZE	SPACING OF DECK JOISTS WITH NO CANTILEVER ^b (in.)			SPACING OF DECK JOISTS WITH CANTILEVER (in.)		
		12	16	24	12	16	24
Douglas Fir- Larch, Hem-Fir, Spruce-Pine-Fir	2x6	9-6	8-8	7-2	6-3	6-3	6-3
	2x8	12-6	11-1	9-1	9-5	9-5	9-1
	2x10	15-8	13-7	11-1	13-7	13-7	11-1
	2x12	18-0	15-9	12-10	18-0	15-9	12-10
Redwood, Western Cedars, Ponderosa Pine, Red Pine	2x6	8-10	8-0	7-0	5-7	5-7	5-7
	2x8	11-8	10-7	8-8	8-6	8-6	8-6
	2x10	14-11	13-0	10-7	12-3	12-3	10-7
	2x12	17-5	15-1	12-4	16-5	15-1	12-4

- a. No. 2 grade.
b. Cantilevered spans not exceeding the nominal depth of the joist are considered "with no cantilever" for this table.

2
S07 Maximum Joist Spans Table From (from 2017 ORSC Table R507.5)
NTS



READY-BUILD PLAN PROGRAM

PRESCRIPTIVE DECK

2017 ORSC

EFFECTIVE
MARCH, 2018

REVISIONS
NO. DATE

Tables

S07

LEDGER CONNECTION TO BAND JOIST^a

CONNECTION DETAILS	JOIST SPAN (ft.), L _j						
	≤ 6	≤ 8	≤ 10	≤ 12	≤ 14	≤ 16	≤ 18
	ON-CENTER SPACING OF FASTENERS (in.)						
1/2-inch diameter lag screw with 1/2-inch maximum sheathing ^{b, c}	30	23	18	15	13	11	10
1/2-inch diameter through bolt with 1/2-inch maximum sheathing ^c	36	36	34	29	24	21	19
1/2-inch diameter through bolt with 1-inch maximum sheathing ^d	36	36	29	24	21	18	16

- a. Ledgers shall be flashed with approved corrosion-resistant flashing applied shingle-fashion in a manner to prevent entry of water into the wall cavity or penetration of water to the building structural framing components in accordance with Section R703.4.
- b. The tip of the lag screw shall fully extend beyond the inside face of the band joist.
- c. Sheathing shall be wood structural panel or solid sawn lumber.
- d. Sheathing shall be permitted to be wood structural panel, gypsum board, fiberboard, lumber, or foam sheathing. Up to 1/2-inch thickness of stacked washers shall be permitted to substitute for up to 1/2-inch of allowable sheathing thickness where combined with wood structural panel or lumber sheathing.

1 Minimum Ledger Connection Table (from 2017 ORSC Table R507.2)
S08 NTS

PLACEMENT OF LAG SCREWS AND THROUGH BOLTS IN LEDGERS AND BAND JOISTS

MINIMUM END AND EDGE DISTANCES AND SPACING BETWEEN ROWS (in.)				
	TOP EDGE	BOTTOM EDGE	CUT ENDS	ROW SPACING
LEDGER ^a	2 ^d	3/4	2 ^b	1 5/8 ^b
BAND JOIST ^c	3/4	2	2 ^b	1 5/8 ^b

- a. Lag screws or bolts shall be staggered from the top to the bottom along the horizontal run of the deck ledger in accordance with detail 3/S04.
- b. Maximum of 5 inches.
- c. For engineered rim joists, the manufacturer's recommendations shall govern.
- d. The minimum distance from bottom row of lag screws or bolts to the top edge of the ledger shall be in accordance with detail 3/S04.

2 Ledger Fasteners Placement Table (from 2017 ORSC Table R507.2.1)
S08 NTS



READY-BUILD PLAN PROGRAM

PRESCRIPTIVE DECK

2017 ORSC

EFFECTIVE
MARCH, 2018

REVISIONS

NO.	DATE

Tables

S08



READY-BUILD PLAN PROGRAM

PRESCRIPTIVE DECK

2017 ORSC

EFFECTIVE
MARCH, 2018

REVISIONS

NO.	DATE

Tables

S09

BEAM SPANS^a, L_B (ft.-in.)

SPECIES ^b	SIZE ^c	DECK JOIST SPAN, L _j , (ft.)						
		≤ 6	≤ 8	≤ 10	≤ 12	≤ 14	≤ 16	≤ 18
Douglas Fir-Larch, Hem-Fir, Spruce-Pine-Fir, Redwood, Western Cedars, Ponderosa Pine, Red Pine	3x6 or 2-2x6	5-5	4-8	4-2	3-10	3-6	3-1	2-9
	3x8 or 2-2x8	6-10	5-11	5-4	4-10	4-6	4-1	3-8
	3x10 or 2-2x10	8-4	7-3	6-6	5-11	5-6	5-1	4-8
	3x12 or 2-2x12	9-8	8-5	7-6	6-10	6-4	5-11	5-7
	4x6	6-5	5-6	4-11	4-6	4-2	3-11	3-8
	4x8	8-5	7-3	6-6	5-11	5-6	5-2	4-10
	4x10	9-11	8-7	7-8	7-0	6-6	6-1	5-8
	4x12	11-5	9-11	8-10	8-1	7-6	7-0	6-7
	3-2x6	7-4	6-8	6-0	5-6	5-1	4-9	4-6
	3-2x8	9-8	8-6	7-7	6-11	6-5	6-0	5-8
	3-2x10	12-0	10-5	9-4	8-6	7-10	7-4	6-11
	3-2x12	13-11	12-1	10-9	9-10	9-1	8-6	8-1

a. Beams supporting deck joists from one side only (with optional joist cantilever).

b. No. 2 grade.

c. Beam depth shall be greater than or equal to depth of joists with a flush beam condition.

1 Maximum Beam Spans Table (from 2017 ORSC Table R507.6)

S09 NTS

POST HEIGHT

SPECIES ^b	DECK POST SIZE	HEIGHT ^a (ft.)
Douglas Fir-Larch, Hem-Fir, Spruce-Pine-Fir, Redwood, Western Cedars, Ponderosa Pine, Red Pine	4x4	8
	4x6	8
	6x6	14

a. Measured to the underside of the beam.

b. No. 2 grade.

2 Maximum Post Height Table (from 2017 ORSC Table R507.8)

S09 NTS



FOOTING DIMENSIONS^a

BEAM SPAN (ft), L _B	JOIST SPAN (ft.), L _J	ROUND FOOTING DIAMETER (in.)	SQUARE FOOTING WIDTH (in.)	MINIMUM FOOTING THICKNESS ^b (in.)
≤ 6	≤ 10	18	16	8
	≤ 14	21	19	8
	≤ 18	24	21	10
≤ 8	≤ 10	20	18	8
	≤ 14	24	22	10
	≤ 18	27	24	11
≤ 10	≤ 10	23	20	9
	≤ 14	27	24	11
≤ 12	≤ 10	25	22	10
≤ 14	≤ 10	27	24	11

a. Assumes 1,500 psf soil bearing capacity per Section R401.4.1.

b. In accordance with Section R403.1.4, footings shall be placed not less than 12 inches below the finished grade on undisturbed ground surface and shall extend below the frost line depth specified in Table R301.2(1). Coordinate footing thickness with post base manufacturer installation instructions.

1 Minimum Footing Sizes Table (Ref 2017 ORSC Section R403)
 S10 NTS

READY-BUILD PLAN PROGRAM

PRESCRIPTIVE DECK

2017 ORSC

EFFECTIVE
MARCH, 2018

REVISIONS

NO.	DATE

Tables

S10

**2017 ORSC TABLE R301.2(1)
CLIMATIC AND GEOGRAPHIC DESIGN CRITERIA^{g,h}**

COUNTY	GROUND SNOW LOAD ^a = 36 psf	ULTIMATE DESIGN WIND SPEED	SEISMIC DESIGN CATEGORY	SUBJECT TO DAMAGE		
				Weathering ^d	Frost line depth (inches)	Decay
Baker	3,200	Note b	Note c	Severe	24	Slight
Benton	400	Note b	Note c	Moderate	12	Moderate
Clackamas	500	Note b	Note c	Moderate	12	Moderate
Clatsop	400	Note b	Note c	Moderate	12	Moderate
Columbia	400	Note b	Note c	Moderate	12	Moderate
Coos	400	Note b	Note c	Moderate	12	Moderate
Crook	4,100	Note b	Note c	Severe	18	Slight
Curry	400	Note b	Note c	Moderate	12	Moderate
Deschutes	4,000	Note b	Note c	Severe	18	Slight
Douglas	1,500	Note b	Note c	Moderate	18	Moderate
Gilliam	3,000	Note b	Note c	Severe	24	Moderate
S.45.5°N		Note b	Note c			
N.45.5°N		Note b	Note c			
Grant	4,100	Note b	Note c	Severe	24	Slight
Harney	4,100	Note b	Note c	Severe	24	Moderate
Hood River	Note e	Note b	Note c	Severe	24	Moderate
Jackson	2,000	Note b	Note c	Moderate	18 ^f	Slight
Jefferson	4,100	Note b	Note c	Severe	18	Moderate
Josephine	4,100	Note b	Note c	Moderate	18 ^f	Moderate
Klamath	4,000	Note b	Note c	Severe	24	Moderate
Lake	4,200	Note b	Note c	Severe	24	Slight
Lane	500	Note b	Note c	Moderate	12	Moderate
Lincoln	400	Note b	Note c	Moderate	12	Moderate
Linn	700	Note b	Note c	Moderate	12	Moderate
Malheur	3,400	Note b	Note c	Severe	24	Slight
Marion	500	Note b	Note c	Moderate	12	Moderate
Morrow	3,000	Note b	Note c	Severe	24	Slight
S.45.5°N		Note b	Note c			
N.45.5°N		Note b	Note c			
Multnomah	500	Note b	Note c	Moderate	18	Moderate
Polk	400	Note b	Note c	Moderate	12	Moderate
Sherman	2,000	Note b	Note c	Severe	24	Slight
S.45.5°N		Note b	Note c			
N.45.5°N		Note b	Note c			
Tillamook	400	Note b	Note c	Moderate	12	Moderate
Umatilla	3,000	Note b	Note c	Severe	24	Slight
S.45.5°N		Note b	Note c			
N.45.5°N		Note b	Note c			
Union	3,000	Note b	Note c	Severe	24	Slight
Wallowa	3,000	Note b	Note c	Severe	24	Slight
Wasco	2,000	Note b	Note c	Severe	24	Slight
S.45.5°N		Note b	Note c			
N.45.5°N		Note b	Note c			
Washington	400	Note b	Note c	Moderate	12	Moderate
Wheeler	4,100	Note b	Note c	Severe	24	Slight
Yamhill	400	Note b	Note c	Moderate	12	Moderate

- a. For locations with elevation higher than the listed values or for a possible reduction in minimum design roof snow load from 25 psf to 20 psf, refer to the Snow Load Analysis for Oregon (including the ground snow load maps) published by the Structural Engineers Association of Oregon in 2007, in conjunction with the 2010 Oregon Snow Load Map update and Interim Guidelines for Snow Load Determination for the State of Oregon, published in 2011.
- b. Refer to Figure R301.2(4) for mapped Ultimate Design Wind Speeds. Wind exposure category shall be determined on a site-specific basis in accordance with Section R301.2.1.4.
- c. Refer to Figure R301.2(2) for mapped Seismic Design Categories.
- d. A severe classification is where weather conditions result in significant snowfall combined with extended periods during which there is little or not natural thawing causing de-icing salts to be used extensively.
- e. For elevations below 500 feet, the ground snow load is 50 psf. Above 500 feet, see Note a.
- f. The frost line depth below 2,500 feet in Jackson and Josephine Counties is 12 inches.
- g. See Section R301.2 and R322 for establishment of flood hazard design criteria.
- h. See Section R327 for establishment of wildfire hazard design criteria.



READY-BUILD PLAN PROGRAM

PRESCRIPTIVE DECK

2017 ORSC

EFFECTIVE
MARCH, 2018

REVISIONS

NO.	DATE

Tables

S11



READY-BUILD PLAN PROGRAM

PRESCRIPTIVE DECK

2017 ORSC

EFFECTIVE
MARCH, 2018

REVISIONS

NO.	DATE

Project Specific
Information

S12

A DECKING [R507.4]:

size: 2x five-quarter
 material: preservative-treated plastic composite naturally durable (e.g. cedar)
 orientation: perpendicular to joists diagonal to joists

B JOISTS [R507.5]:

size: 2x6 2x8 2x10 2x12
 spacing: 12 in. 16 in. 24 in.
 span, L_J: ___ ft. - ___ in.
 cantilever: ___ ft. - ___ in. (L_J/4 MAX)
 rim joist: 2x6 2x8 2x10 2x12 not applicable

C BEAMS [R507.6]:

plies: 1 2 3
 size: 2x6 2x8 2x10 2x12 4x6 4x8 4x10 4x12 __x__
 span, L_B: ___ ft. - ___ in.
 cantilever: ___ ft. - ___ in. (L_B/4 MAX)

D POSTS [R507.8]:

size: 4x4 4x6 6x6 __x__
 height: ___ ft. - ___ in.

E FOOTINGS [R507.8.1]:

size: ___ in. square round
 thickness: ___ in.

F LEDGER [R507.2]:

size: 2x8 2x10 2x12
 fastener: 1/2" through-bolt 1/2" lag screw code-compliant alternate (attach report)
 fastener spacing: ___ in. on-center

G LATERAL LOAD CONNECTION [R507.2.4]:

(4) 750 pound hold-down tension devices (detail 1/S04)
 (2) 1,500 pound hold-down tension devices (detail 2/S06)
 code-compliant alternate (attach report)

H GUARDRAIL POST ATTACHMENT [R301.5]:

details 1-3/S05 & 1/S06
 code-compliant alternate (attach detail).

NOTE: THE PERMIT APPLICANT SHALL PROVIDE THE PROJECT SPECIFIC DESIGN BY CHECKING THE APPLICABLE BOXES AND ENTERING THE APPROPRIATE INFORMATION ABOVE PRIOR TO PERMIT APPLICATION.

1 Project Specific Information
 S12 NTS